

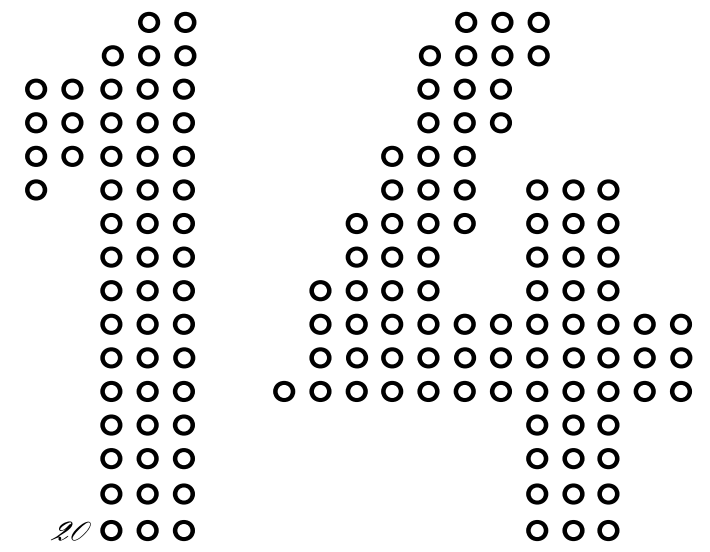

moioⁱ



20

the unexpected welcome



NIKA ZUPANC



ZMIK



FRESH WEST



JURGEN BEY



RICHARD HUTTEN

photo Arre Kleivt



SJOERD VROONLAND



JAIME HAYON



BERTJAN POT

photo Cornelle de Jong



RODERICK VOS

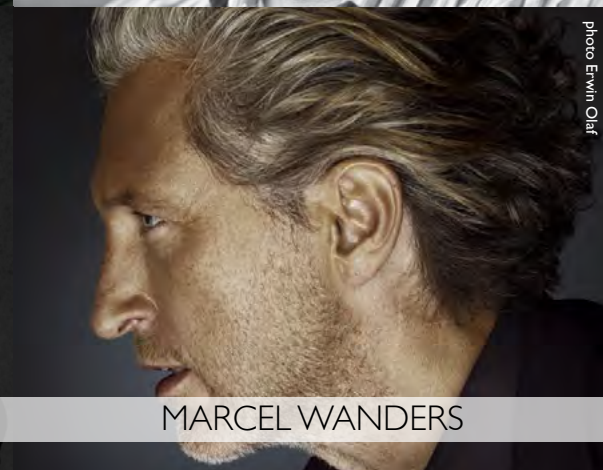

MARCEL WANDERS

photo Erwin Olf



JOEL DEGERMARK



RON GILAD

photo Monica Castiglioni

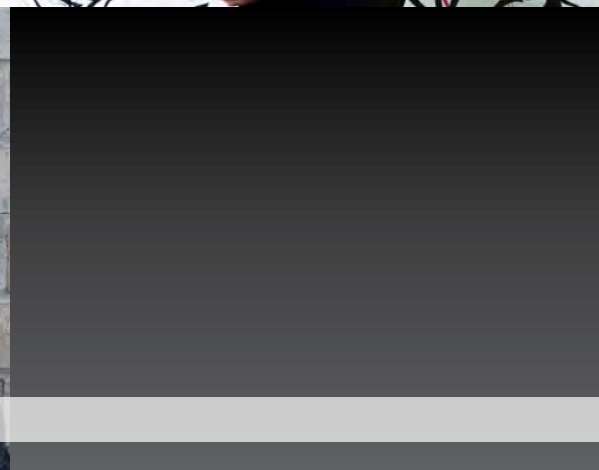

JASPER MORRISON

photo Siki Dhandia

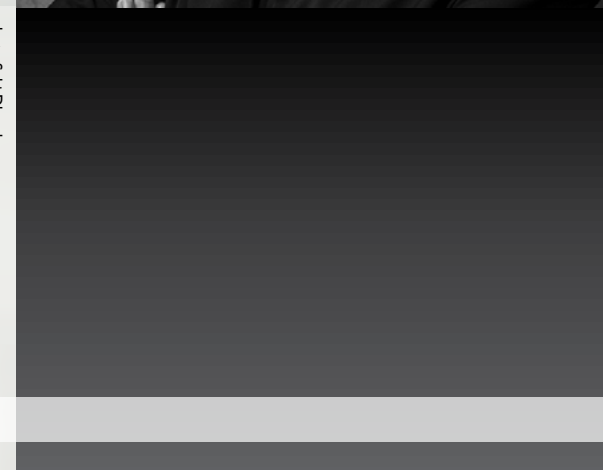

STUDIO JOB

photo R. Sroop



JOOST VAN BLEISWIJK



STEFANO GIOVANNONI



NERI & HU

photo Pedro Figenaute

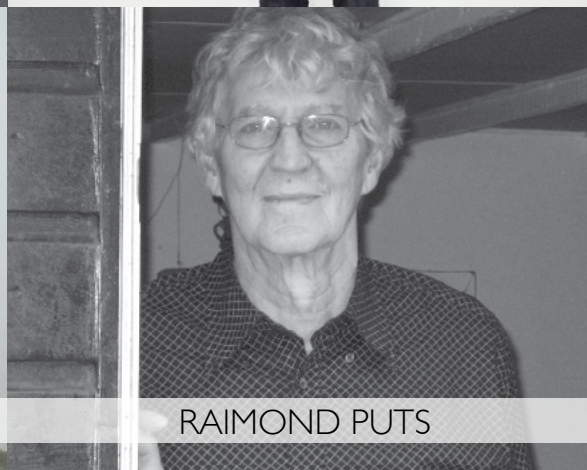

RAIMOND PUTS



MAARTEN BAAS

photo Sarah Jane

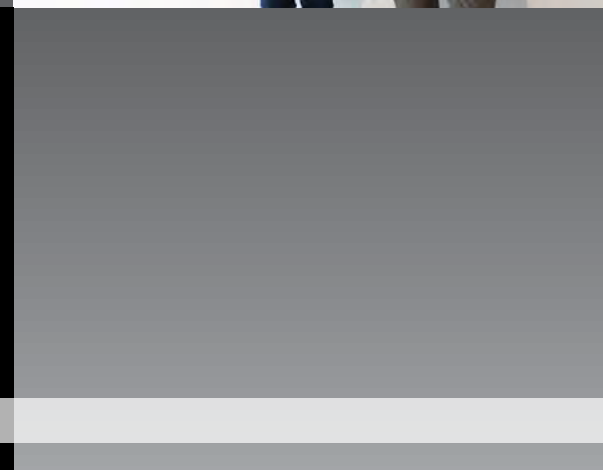

LORENZA BOZZOLI



FRONT

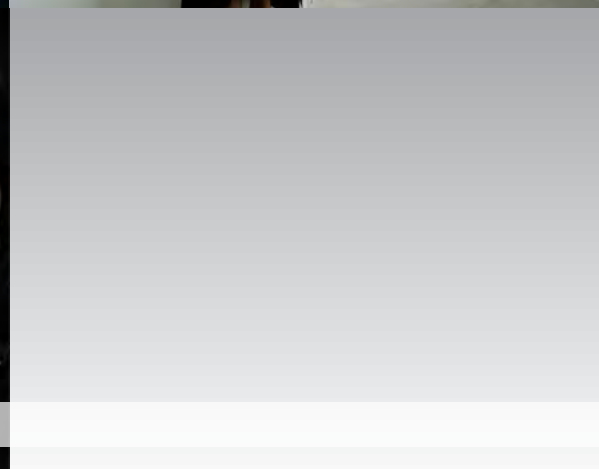

PIET BOON

photo Rahi Rezvani

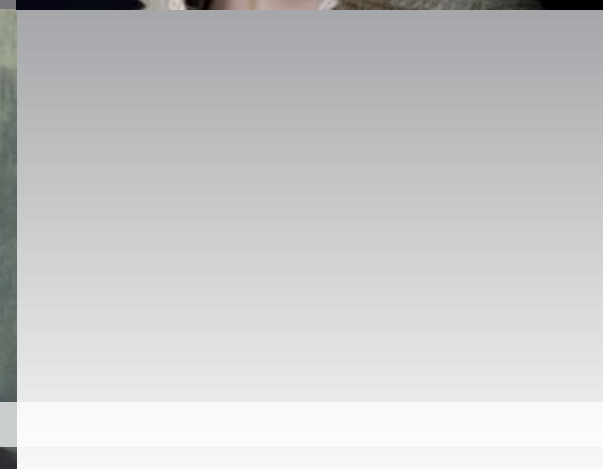

EDWARD VAN VLIET



ARIHIRO MIYAKE

photo Valentina Follì

FLOOR LAMPS

Brave New World Lamp	046 068 071 073 075 182
Bucket Floor Lamp	007 099 112 122 165 182
Construction Lamp	022 068 090 093 106 109 145 160 163 169 182
Dandelion Floor Lamp	175 179 182
Double Shade	006 105 182
Emperor Floor Lamp	139 148 182
Farooo	028 050 054 119 133 182
Horse Lamp	057 083 183
Light Shade Shade Floor Lamp	083 183
Lolita Floor Lamp	156 183
Miyake 110	018 086 183
Paper Floor Lamp	053 075 172 183
Random Light LED Floor lamp	020 084 085 100 183
Set up Shades	028 038 039 053 129 183
Trix	183

SUSPENSION LAMPS

Bell Lamp	022 028 030 031 184
Bucket Lamp	007 155 184
Clusterlamp	141 184
Dandelion	178 184
Dear Ingo	097 146 156 184
Emperor	114 184
Hang	184
Heracleum II	021 116 171 184
Heracleum II Small	042 043 126 145 184
Heracleum The Big O	023 025 099 169 185
Juuyo	049 060 139 185
Kroon 7 & 11	102 185
Light Shade Shade	048 185
Lolita	185
Long Light	185
Mistral	185
Non Random	075 079 134 185
Oval Light	185
Paper Chandelier	031 061 133 186
Raimond R43 & R61 & R89	013 057 068 090 130 156 186
Raimond Zafu	186
Raimond R127, R163 & R199	087 186
Raimond Dome	012 067 186
Random Light	035 119 148 150 175 186
Random Light LED	008 140 186

Round Boon	186
Round Light	186
Smoke Chandelier	187
Square Boon	186
Square Light	186
Tub Lamp	121 187
Tube	187
Valentine	089 090 162 187
Valentine Flat	157 187

TABLE LAMPS

Double Round Light	057 141 187
Double Square Light	187
Emperor Table Lamp	053 142 172 187
Kaipo Too	040 044 063 187
Lolita Table Lamp	058 059 187
Mask Lamp	040 116 135 188
Miyake 60	068 086 090 136 188
Paper Table Lamp	061 065 075 166 188
Rabbit Lamp	101 151 188

SECRETARY

Two Tops Secretary	027 059 092 142 188
Wood	068 083 090 108 109 136 188

SIDE TABLE

Chess Table	006 150 159 188
Common Comrades	098 099 124 125 126 141 148 152 188
Corks	071 135 171 189
Crochet Table	040 071 189
Paper Side Table	018 022 169 189
Pig Table	076 189
Urban Hike	068 090 173 175 189

TABLES

Container Table ø70 70x70 80x80	043 075 102 116 190
Container Table ø90 90x90	057 190
Container Table ø120 120x120 ø140	007 022 190
Container Table ø160 160x160 ø180	012 190
Container Table 80x180	190
Container Table New Antiques	007 016 126 166 190
5 O'Clock Table	189

Paper Table	030 139 189
Two Tops Table	024 189

ACCESSORIES

Altdeutsche Clock	059 099 125 192
Big Ben	027 051 092 192
Blow Away Vase	027 192
Bold	099 126 169 192
Carpet No. 01-12	119 192
Carpet No. 14	066 193
Carpet No. 15-16	105 193
Container Bowl	193
Container Vase	194
Delft Blue	020 022 034 079 112 135 152 194
Egg Vase	010 024 080 081 165 194
Elements	006 010 020 053 068 080 084 090 101 119 165 172 194

Foam Bowl	081 194
Frame	035 194
Frame Mirror	194
Ming Vase	081 195
Paper Mirror	068 195
Paper Screen	012 038 122 133 145 195
Sponge Vase	081 195
The Killing of the Piggy Bank	195
Heritage & Oil Pillows	006 009 010 011 080 119 152 165 195

CHAIRS

Carbon Chair	068 083 090 136 137 139 196
Container Stool	196
Extension Chair	008 059 142 143 196
Golden Chair	022 026 027 092 196
Gothic Chair	007 078 155 196
Monster Barstool & Chair	012 014 079 102 196
New Antiques Barstool	075 196
New Antiques Container Stool	016 030 040 096 109 126 197
5 O'Clock Chair	197
Smoke Dining Chair	057 177 197
Smoke Dining Armchair	131 197
V.I.P. Chair	024 028 121 158 197

ARMCHAIRS

Bart Canape Armchair	197
Bart Armchair	038 068 175 197
Bottoni	197
Bottoni Slim	171 198
Boutique, single seaters	036 054 125 129 198
Labyrinth Chair	112 118 122 156 198
Smoke Chair	160 161 198

SOFAS

Bart Canape	198
Bart Sofa & Daybed	053 068 094 090 172 175 198
Bart XL Sofa	040 071 199
Bottoni	105 156 199
Bottoni Shelf	199
Bottoni Slim	199
Boutique, double seaters	035 199
Boutique triple seaters	035 051 054 061 199 200 201
Boutique footstool	198
Canvas Sofa	006 009 010 080 106 119 125 145 160 163 165 201s018 020 046 073 075 084 099
Cloud Sofa	100 126 133 201
Zliq Island	089 169 202
Zliq Sofa	023 025 141 148 201

STORAGE

Altdeutsche Chest	128 179 202
Altdeutsche Cabinet	127 129 202
Oblique	101 202
Paper Buffet	033 075 090 139 202
Paper Cabinet	006 053 064 150 155 166 203
Paper Cupboard	028 072 075 121 203
Paper Wardrobe	030 040 046 073 203



DOUBLE SHADE
 CHESS TABLE
 PAPER CABINET RAL
 CANVAS SOFA + HERITAGE & OIL PILLOWS
 ELEMENTS 002 & 007

BUCKET LAMP
 BUCKET FLOOR LAMP
 GOTHIC CHAIR
 CONTAINER TABLE NEW ANTIQUES
 PAPER CABINET RAL



RANDOM LIGHT BLACK
EXTENSION CHAIR

CANVAS

MARCEL WANDERS 2012

Enjoy the comforts of a cosy lounge & sofa that makes you feel like an expert art lover, sitting on a canvas of hazy dreams. The soft pillows are the paintings produced by the artistic imagination of Marcel Wanders, embodying the dynamic soul of the art that we can admire at the

Hermitage & Rijksmuseum.

Cherish the elegance of the black and white symphony of graphic motives depicted on the Heritage Pillows, or the luscious richness of the abstract deep red strokes portrayed on the Oil Pillows. The pillows are sold in sets of three.





CANVAS SOFA
HERITAGE PILLOWS
ELEMENTS NO. 2
EGG VASES



HERITAGE PILLOWS *by Marcel Wanders 2012*



RAIMOND DOME
MONSTER ARMCHAIR & MONSTER CHAIR
CONTAINER TABLE
PAPER SCREEN RAL

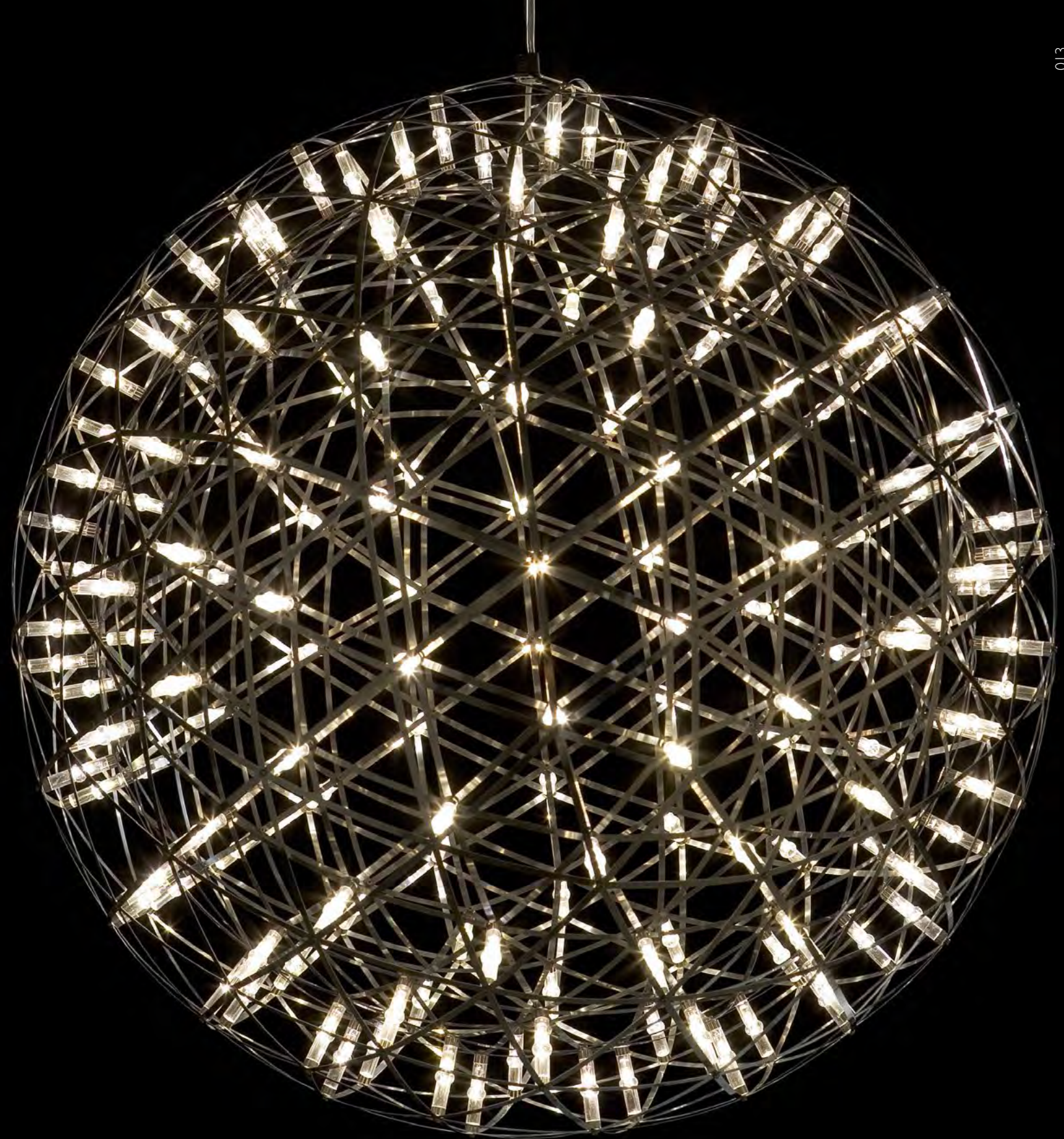

RAIMOND

RAIMOND PUTS IN ASSOCIATION WITH OX-ID 2007

The Raimond lamp is based on the pure beauty of mathematics. Its creator, Raimond Puts, has been busy developing the concept of this extraordinary lamp for a great part of his life.

It all started with the discovery of the geometric shape of a football that brought him to consider round shapes formed by triangles. Hundreds of stainless steel strips intersect creating triangles that converge into a perfectly round globe. The poetry of a sphere composed by straight lines. His love for the absolute and fundamental sciences inspired questions that tickled him for years, until the Raimond lamp as we know it was finalized and became part of the Moooi collection in 2009. Authentic and extremely complex at the same time.

The Raimond lamp: a perfect sphere of mathematical ingredients punctuated by tiny LED lights. Looking at the lamp feels like staring into the soft glow of a starry night. Into the essence.

Raimonds for USA and CA markets have different specifications, for more details please check the product information on www.moooi.com



MONSTER BARSTOOL LOW & MONSTER BARSTOOL
MARCEL WANDERS 2010



DETAIL CLOUD SOFA

CONTAINER TABLE NEW ANTIQUES & CONTAINER STOOL NEW ANTIQUES
MARCEL WANDERS 2011



Heraclium by Bertjan Pot, concept & photography by Marcel Wanders & Erwin Olaf



CLOUD SOFA
 MIYAKE 110
 PAPER SIDE TABLE RAL

MIYAKE 60 & 110
 ARIHIRO MIYAKE 2009



DELFT BLUE NO. 2 & DELFT BLUE NO. 9.2
RANDOM LED FLOOR LAMP MEDIUM WHITE
ELEMENTS NO. 2
CLOUD SOFA



HERACLEUM II

BERTJAN POT, POWERED THROUGH ELECTROSANDWICH® BY MARCEL WANDERS 2010
Decorative LED lamp inspired by the Heracleum plant. The white leaves/lenses ramify from one branch creating a very technical, natural structure. By using the innovative and recently developed electrosandwich technology by Marcel Wanders, Heracleum is very thin and delicate.



THE GOLDEN CHAIR
 CONTAINER TABLE NEW ANTIQUES
 DELFT BLUE NO. 11
 BELL LAMP
 CONSTRUCTION LAMP L & S
 PAPER SIDE TABLE RAL
 DELFT BLUE NO. 9.2

ZLIQ ISLAND
 PAPER SIDE TABLE RAL
 DELFT BLUE NO. 6
 CONSTRUCTION LAMP M
 HERACLEUM THE BIG O



HERACLEUM THE BIG O

BERTJAN POT 2012

ZLIQ ISLAND

MARCEL WANDERS 2012

They say that no man is an island, but what about enjoying your own private island within the safe walls of home? This new concept is created by two Zliq sofas facing each other, with the addition of an extra component in between. When you have enjoyed enough privacy for the day, you can roll away the in-between module and invite other people to enjoy the treasures of your very own Zliq Island.



THE GOLDEN CHAIR

NIKA ZUPANC 2012

Modest in its form and logical in the choice of materials: this reincarnation of a retro-looking school chair calls for a shiny aureole.

With dipping it into gold comes a sublime effect. The restrained thinking behind its design is as far away as possible from the idea of a throne chair, yet its presence has a fairytale quality to it.

It is politically incorrect of course, like champagne revolutionarism, but its voice is of the noblest sort: loud silence.





FAROO
BELL LAMPS
V.I.P CHAIR
PAPER CUPBOARD PATCHWORK
SET UP SHADES



BELL LAMPS
 PAPER TABLE PATCHWORK
 CONTAINER STOOL NEW ANTIQUES
 PAPER WARDROBE RAL
 BELL UPLIGHTER

BELL LAMPS

MARCEL WANDERS 2013

The bell represents a very early and essential form of communication, generating a welcoming ring that brings people together for festivities and congregations. It has always been a fundamental icon for Marcel Wanders, who, after using its soft shapes for his Personal Editions, now extends it to the Moooi collection by introducing the Bell pendant. The bell-shaped glass shades are decorated with a festive ceramic bow.





PAPER CHANDELIER XL WITH SHADES

PAPER BUFFET PATCHWORK
STUDIO JOB 2012

Paper Patchwork by Studio Job is a new member of Moooi's renowned Paper Collection family. Paper Patchwork which is a playful patchwork of sparkling colours combined with the purity of natural wood, like in old fashioned cars or in the patchwork quilts carefully sewed by our favorite aunt. So enjoy mixing & matching them in any kind of interior!
To discover all colour and patterns possibilities for this design, please visit our website: www.moooi.com





DELFT BLUE NO. 6



BOUTIQUE DOUBLE SEATER JESTER
BOUTIQUE FOOTSTOOL JESTER
FRAME
RANDOM LIGHT



PAPER SCREEN RAL
 SET UP SHADES 6
 BART ARMCHAIR



SET UP SHADES
 MARCEL WANDERS 1989

Exploring the boundaries within type-forms Marcel Wanders presents the 'Set Up Shades' for this intriguing collection.



BART SOFA XL
MASK LAMP
KAIPO TOO
CROCHET TABLE
PAPER WARDROBE RAL
CONTAINER STOOL NEW ANTIQUES



HERACLEUM II SMALL
BERTJAN POT 2012
 powered through electrosandwich by Marcel Wanders

CONTAINER STOOL NEW ANTIQUES
 CONTAINER TABLE NEW ANTIQUES
 HERACLEUM II SMALL





KAIPO TOO, SMOKE



DETAIL KAIPO TOO SMOKE

CLOUD SOFA
BRAVE NEW WORLD
PAPER WARDROBE PATCHWORK
PAPER TABLE LAMP RAL





LIGHT SHADE SHADE FLOORLAMP
 LIGHT SHADE SHADE Ø70
 JURGEN BEY (DROOG DESIGN) 1999



JUUYO BY LORENZA BOZZOLI

The two lamps by Lorenza Bozzoli immortalize the soft shapes, graceful prints and vibrant colours that represent the essence of a sensual cultural heritage from the Eastern world: the glamorous, poetic & witty Geisha figures and their earlier predecessors, the Juuyo.

Peach Flowers: Soft, delicate peach flowers find their way into the heart of the lamp and steal a part of it to bloom & protect its owner against the forces of evil. They bring renewal, beauty, youth and rebirth to whoever is touched by the lamp's light. An ancient talisman against darkness...

Koi Carp Tattoo: The sweetest, most vibrant koi carp cuts itself a central position in the rounded shapes of the lamp and glides through a stream of flowers, resembling a vivid tattoo and symbolizing courage & the will to achieve great things. One of the most beloved symbols in Japan!







BART SOFA
 BART DAYBED
 SET UP SHADES
 ELEMENTS 007
 ELEMENTS 005
 EMPEROR TABLE LAMP
 ELEMENTS 003
 PAPER FLOOR LAMP
 PAPER CABINET PATCHWORK



FAROO
 BOUTIQUE TRIPLE SEATER COF
 BOUTIQUE SINGLE SEATER TRAVIS



DETAIL VALENTINE FLAT



INK AIRBORN
SMOKE DINING CHAIR
CONTAINER TABLE
CONTAINER VASE
HORSE LAMP
DOUBLE ROUND LIGHT
RAIMOND

*who is
afraid
of pink...?*

LOLITA TABLE LAMP
NIKA ZUPANC 2008

"...My imagination chases female archetypes intentionally. Frivolous, even naïve objects are my favorite victims. And when, during such a process, I manage to be creative in an evidently reserved way, I then touch the purest meaning of my work and frivolity becomes timeless elegance. Lolita is here to play with your emotions. She is here to break your everyday routine."



ALTDEUTSCHE CLOCK
TWO TOPS SECRETARY
LOLITA TABLE LAMP
EXTENSION CHAIR



DETAIL JUUYO PEACH FLOWERS



BOUTIQUE TRIPLE SEATER
PAPER CHANDELIER L
PAPER TABLE LAMP



KAIPO TOO
EDWARD VAN VLIET 2012

After a sparkling youth wrapped in its silver outfit, Kaipo has had all the time to reflect on its deeper meaning. It has matured and developed to the next stage of its life, Kaipo TOO, a grown-up version with the same potential and an evolved insight & sense of self. Its designer, Edward van Vliet, understood this process and provided Kaipo with a dress made of glass, disclosing its pure essence with renewed strength... unafraid of revealing a heart as clear as glass!



PAPER CABINET PATCHWORK



PAPER TABLE LAMP PATCHWORK
STUDIO JOB 2012

FIRMSHIP CARPET

STUDIO JOB 2010

"The design of the carpet finds its origin in the nautical iconography.

Originally Nynke Tynagel designed the pattern for the facade of a big building at the harbor of Rotterdam. Last year we used it again in the boat and offices we designed for a brand new company called Firmship. As always... Moooi pirate's keen eyes spot everything and invited us to do a composition for this carpet!"

by Job Smeets



RAIMOND DOME 79,

RAIMOND PUTS 2012

On a warm summer night, when everything is concealed, we stare into the soft glow of the sky, into the essence. Under the starry dome we dream away, seeking answers ... losing ourselves into a galaxy of twinkling spheres, we can easily spot the number one star; the biggest one at the centre of the sky. Raimond Dome brings the poetry of a starry night to our homes, having a powerful lamp right at the centre of its dome-shaped network of twinkling LED lights. This makes it the perfect reading or dining lamp.

BART SOFA
BART ARMCHAIR
URBAN HIKE
ELEMENTS 006
ELEMENTS 005
BRAVE NEWWORLD
CONSTRUCTION LAMP
PAPER MIRROR
WOODD
MIYAKE 60
CARBON CHAIR
RAIMOND





DETAIL BRAVE NEW WORLD



BRAVE NEW WORLD LAMP

FRESH WEST 2008

The Brave New World Lamp started as a concept piece of random thought-initiated construction. Inspired by the traditional Far Eastern bamboo scaffolding, The Brave New World Lamp was developed without a design or plan in place. However each piece of wood is carefully notched and pegged together to form an integral part of the overall mechanical mechanism. The limitations of using small pieces of wood to create a large form allowed the design process to be as responsive as possible. Much like a sculptures' relationship to their material.



PAPER CUPBOARD
STUDIO JOB 2005

PAPER COLLECTION STUDIO JOB

Did the idea of paper furniture ever strike your mind?

Paper, cardboard and papier-mâché are familiar to all of us. They bring back long-lost memories of kindergarten and our first experiences of making things with our own hands, coloring, cutting, shaping and wrapping like busy bees. We can generate almost anything from a white sheet of paper: from basic shapes and everyday objects to dramatic love letters and life-changing novels. It is a material with infinite potential, waiting for the dreamer to give it a shape.

Inspired by classic icons but manufactured like modern day furniture, this cardboard flat pack furniture collection is an ode to a classical style and to a material that makes everything possible. Even hanging your clothes or storing your shoes in a solid piece of furniture made of paper!



BRAVE NEW WORLD
CLOUD SOFA
PAPER WARDROBE PATCHWORK



PAPER BUFFET PATCHWORK
PAPER TABLE LAMP PATCHWORK
NON RANDOM
CONTAINER TABLE NEW ANTIQUES
NEW ANTIQUES BARSTOOL
BRAVE NEW WORLD
CLOUD SOFA
PAPER CUPBOARD PATCHWORK
PAPER FLOOR LAMP PATCHWORK

PIG TABLE!



PIG TABLE
FRONT 2006

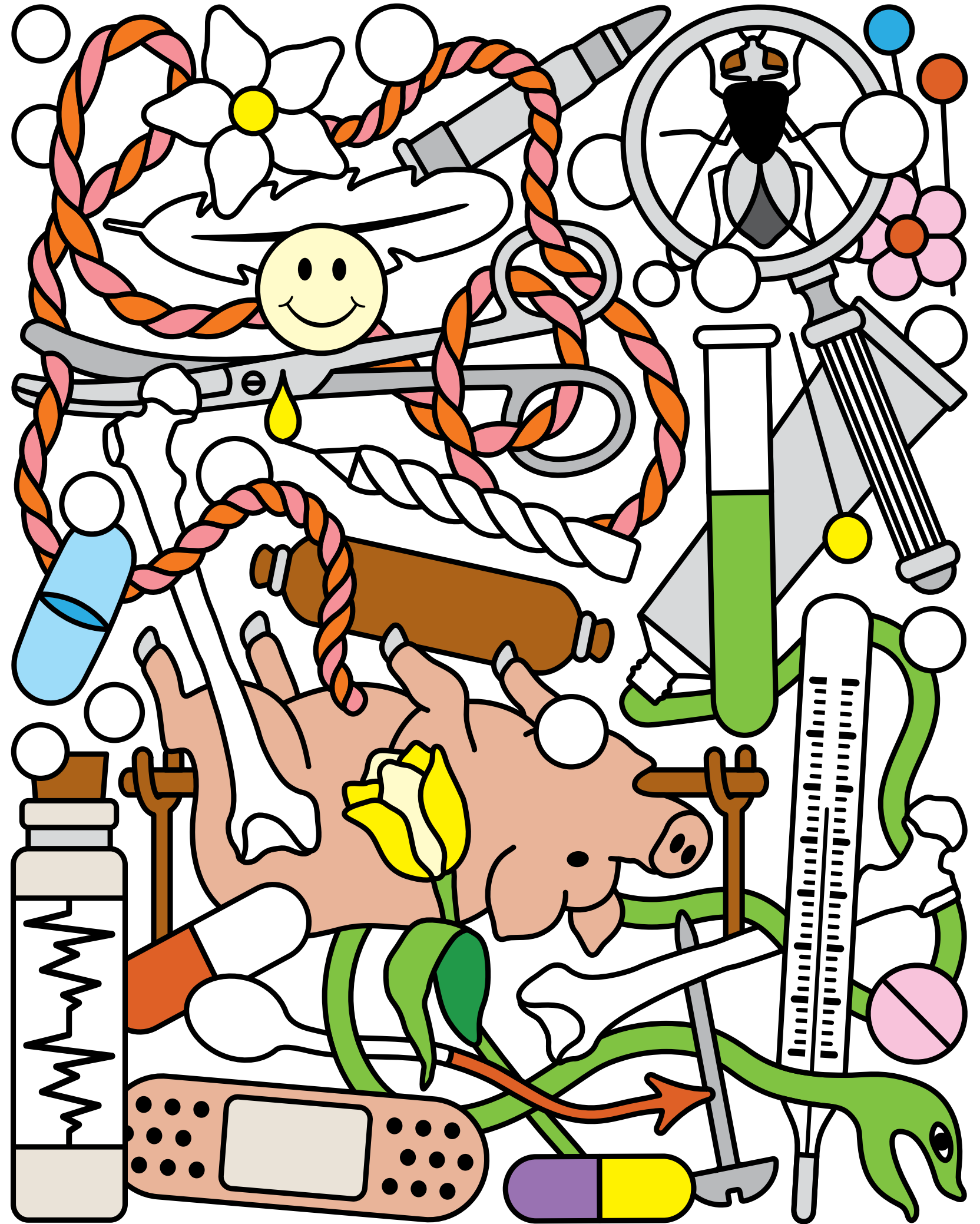

DETAIL ALTDEUTSCHE PATTERN, STUDIO JOB

GOTHIC CHAIR
STUDIO JOB 2010

“And then, of course, there is Moooi, the eccentric company with which Nynke and I have been fortunate to work with for some years.

The Paper collection of 11 products has done well, and we felt it was time to offer a Studio Job chair. I bought a magnificent 16th century style, neo-Gothic chair in an antique shop and put it on the table at Moooi, proposing that this complex handcrafted archetype be produced by the industrial method of rotational moulding. Studio Job drew up a design that acknowledged all the limitations of rotational moulding without sacrificing the character of the original model. The Gothic Chair was born lucky right from the beginning. An affordable and functional archetype for indoors and out, available in a bright spectrum of ten colours.”

by Job Smeets





HERITAGE PILLOWS
CANVAS SOFA
ELEMENTS 002
EGG VASES
BUCKET FLOOR LAMP

EGG VASE, FOAM BOWL, SPONGE VASE & MING VASE

MARCEL WANDERS 1997

Vases molded with boiled eggs and rubber condoms. Simple, unexpected everyday elements converge to create beauty.

One of the first constructive things that we spontaneously do in life is play. Already at a very young age we start discovering the world around us, challenging our skills and experiencing reality by playing with it. Molding materials with our hands, creating and destroying things with the same fervor of a bunch of restless madmen.

As we grow up many of us decide that we have learnt enough and put a stop to the games...

Fortunately Marcel Wanders has not put a stop to games and fun so easily. He has actually translated his creative qualities into a profession and, unlike many others, has succeeded to build a great international reputation in the design sector by molding and experimenting, playing with reality and ideas, using his imagination and developing it into a powerful and entertaining creative tool.

One day he had the bizarre idea of designing a porcelain accessory in the soft, curvy shape of a pile of eggs. But what kind of object could that become? And how would he give it the desired shape? And at last two brilliant ideas were born: why not boil a bunch of eggs, insert them in rubber condoms for protection and mold the porcelain around them? And why not create a bizarre, soft, resistant egg vase? In the matter of minutes a groundbreaking idea was conceived and soon after the Egg Vase came to life, becoming a part of people's homes, offices and lives.





LIGHT SHADE SHADE FLOOR LAMP
WOOD
CARBON CHAIR
HORSE LAMP



RANDOM LIGHT LED FLOOR LAMP S & M
ELEMENTS 005
CLOUD SOFA
ELEMENTS 002



RANDOM LIGHT LED FLOOR LAMP S & M
BERTJAN POT 2010



MIYAKE 110
MIYAKE 60



Behalve den man, die de Sarphatistraat de mooiste plek van Europa vond heb ik nooit een wonderlijker kerel gekend als den uitvreter. (Eerste zin van 'De Uitvreter' - Nescio)

RAYMOND

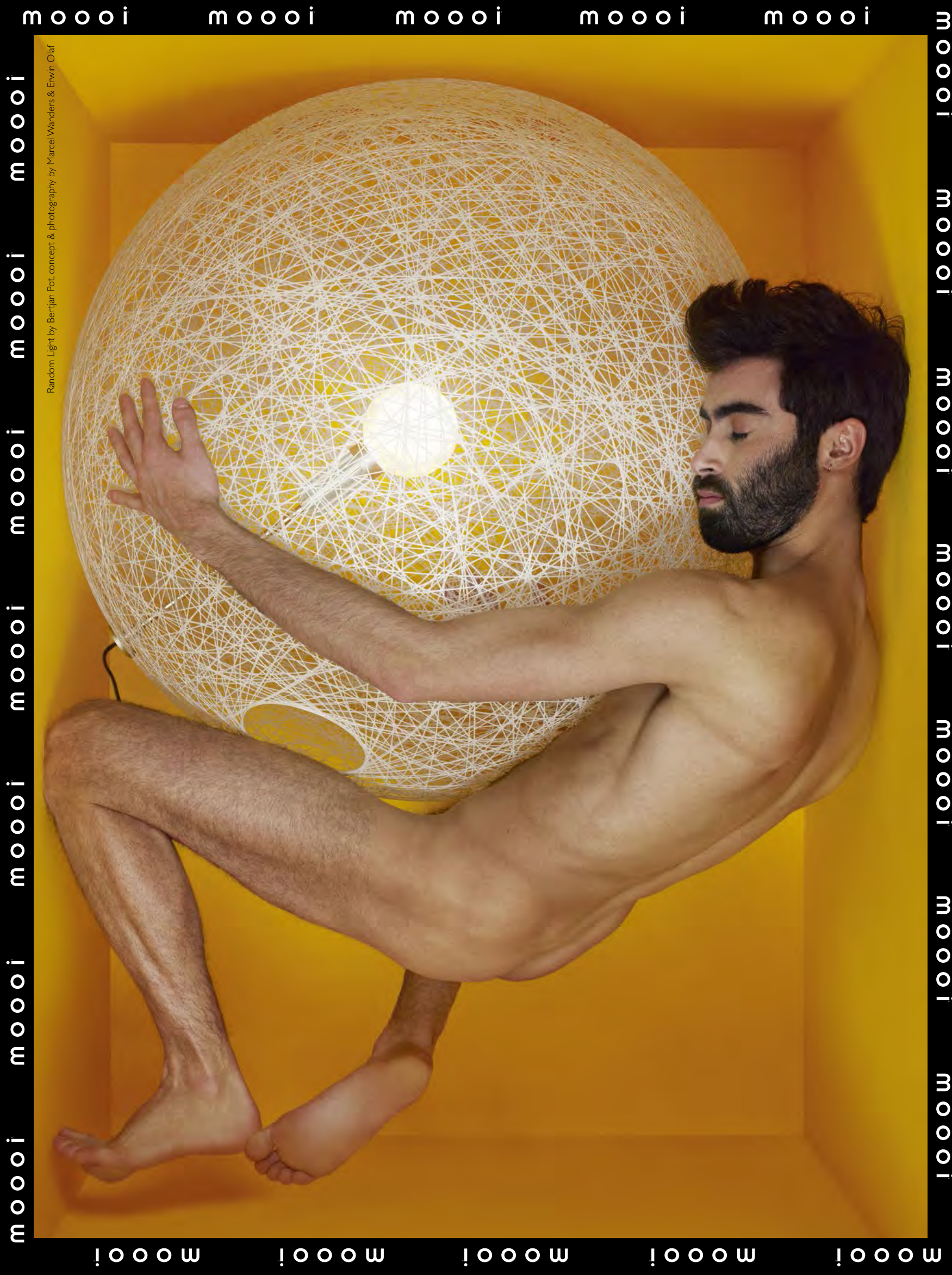

Random Light by Bertjan Pot, concept & photography by Marcel Wanders & Erwin Olaf



VALENTINE *Marcel Wanders 2011*



ZLIQ *Marcel Wanders 2012*



CONSTRUCTION LAMP
 PAPER SIDE TABLE
 URBAN-HIKE
 PAPER BUFFET RAL
 VALENTINE
 ELEMENTS 005
 ELEMENTS 006
 BART SOFA
 RAIMOND
 WOOD
 CARBON CHAIR
 MIYAKE 60



092

BIG BEN
TWO TOPS SECRETARY
THE GOLDEN CHAIR
BLOW AWAY VASE
SMOKE DINING ARMCHAIR



093

CONSTRUCTION LAMP

JOOST VAN BLEISWIJK 2012

Inspired by the vast number of combinations possible with the tools and bolts present in his giant workshop, Joost van Bleiswijk started playing with them and ended up constructing and creating a new, exciting design! The Construction lamp ultimately originates from a bright curiosity combined with expert skills, industrial tools and a touch of playful passion for vintage construction toys. As a result, the lamp's details and joints take the shape of Victorian cast iron components & become part of a base that resembles a traditional electricity pole. Enjoy a high voltage stream of inventiveness and light!



BART DAYBED
MOOOIWORKS | BART SCHILDER
2012

Have you ever thought of bringing a touch of grandeur to your home, without conveying the firm austerity of real antiques?

The Bart Family collection of sofa's, armchairs, daybed and canapés is originally inspired by the rounded shapes & sumptuous glory of 18th century Rococo.

Moooli works / Bart Schilder reinterprets such splendor, adding genuine pleasure and softness to the classic silhouette by using modern day skills and a timeless eye for detail.

Square angles are tempered and smoothed into the round coziness of curved shapes & features for extra comfort. Enjoy 'rounding' off your home with the friendly tenderness of the Bart Family components!





NEW ANTIQUES BARSTOOL & NEW ANTIQUES BARSTOOL LOW
 MARCEL WANDERS 2012
 The New Antiques family is so versatile that it rapidly grows and has generated a charming new family member to introduce during this fervid design season. The Container New Antiques Barstool complements its hard, voluptuous body with the softness of a cosy pillow and the comfort of a relaxing footrest. A vintage blend of antique and new with a hint of flirtatious playfulness!





COMMON COMRADES
NERI & HU 2013

A clever personification of the simplicity of country life, where everybody knows 'who' you are and 'what' you do, the Common Comrades table family amuses us with its utilitarian simplicity & honest soul. The Seamstress, the Tailor, the Merchant, the Scholar, the Farmer and the Emperor have one thing in common: they are all identified and defined by their function as members of a group, as true comrades. The wooden tables, all a bit different from each other in aspect, work to a common purpose with the same dedication of the people they represent... making a real group effort to bring comfort and style.



HERACLEUM THE BIG O
BUCKET FLOOR LAMP
COMMON COMRADES
CLOUD SOFA
BIG BOLD
ALTDEUTSCHE CLOCK



RANDOM FLOOR LAMP LED
CLOUD SOFA
ELEMENTS 002



OBLIQUE BIG
MARCEL WANDERS 2002

RABBIT LAMP
FRONT 2006

ELEMENTS
JAIME HAYON 2007

Inspired originally by the form of a cactus and its modular shape, the various parts of the Elements collection resemble a functional sculpture: as beautiful as the cactus, but extremely versatile in their combinations and use.

The initial thought was to design a series of stackable stools in different materials. Then, luckily, a simple question was asked that turned everything around: "why should they all be stools?" This led to a new concept where each piece of the stackable sculpture would have a different use: mirror, table, tray, etc. A variety of colours, materials and finishes were applied to each vertebra making the whole body of the sculpture richer and more flexible. From a cactus to a sculpture of different functional Elements.



KROON 7 & KROON 11, ZMIK, MATTIAS MOHR & ROLF INTERMÜHLE 2011

Are you looking for a contemporary twist on the classic chandelier? And do you dream of a lighter & more versatile lamp, capable of magically transforming itself? Then Kroon by ZMIK (Mattias Mohr & Rolf Intermühle) is certainly your design charm!
The Kroon lamps reinterpret the past glamour and transfer it into present technologies - LED powered light tubes - and into a contemporary & sophisticated star-like silhouette. Their frame glows and breathes at your wish...contracting and expanding like a radiant heartbeat.





DETAIL KROON II



BOTTONI
DOUBLE SHADE
CARPET NO. 15, FATA MORGANA TJ ONE



CONSTRUCTION LAMP
CANVAS SOFA



DETAIL CONSTRUCTION LAMP



WOOD

MARCEL WANDERS 2010

A PERSONAL DESK TOP. A PRIVATE HOME OFFICE.
A SIDED SIDE TABLE.
A FRUITBOWL FOR YOUR APPLES.



WOOD
CONTAINER STOOL NEW ANTIQUES
CONSTRUCTION LAMP



LABYRINTH CHAIR, ORIGINAL
DELFT BLUE NO. 6
BUCKET FLOOR LAMP



DELFT BLUE NO. 8



HERACLEUM II
MASK LAMP



CONTAINER TABLE
MARCEL WANDERS 2001

The Container-Table concept is a fully versatile system that has endless composition possibilities to fit in any space. With combinations to suit your home, office or public space the Container-Table can certainly exceed any requirements.

material: polyethylene (PE), stainless steel inserts and HPL mounting plate
the foot must be filled with sand or water to create extra stability, the Container-Tops are available in 3 different high quality materials to match your Container-Foot, the size of the top defines the size of the foot.



LABYRINTH CHAIR *Studio Job 2012*

Originally designed as an ode to glorious moments, this archetypal chair is endowed with a majestic figure and a strong personality. The sumptuousness of its silhouette is accentuated by the intense vivacity of its colours and prints. Three chairs with individual outfits to 'accommodate' different kind of people: green or grey labyrinths for those who are not scared of losing their way in an intricate network of possibilities, or an industrious swarm of insects for those who like to keep busy & always enjoy creating a buzz! Which one is the perfect fit for you?



CANVAS SOFA
HERITAGE PILLOWS
RANDOM LIGHT
ELEMENT 007
PAPER SIDETABLE
FAROOO





PAPER SCREEN PATCHWORK
LABYRINTH CHAIR, GREY
BUCKET FLOOR LAMP



BUCKET LAMPS
STUDIO JOB 2012

"Whoever said that designers cannot be pragmatic? The Bucket lamps and Tub lamp by Studio Job are playful interpretations of pragmatic solutions found to the practical challenges of every day's life. Buckets and tubs aren't necessarily just tools used outdoors by workers or farmers and then stored away for the night... They are decorated with luxurious brass and ceramic details to become the true trophies of a public room or the sparkling jewels of an intimate home environment, bringing 'buckets' of light and 'tubs' of character to any interior. So designers can certainly be pragmatic... just not in the traditional sense of the word!"



SEAMSTRESS

EMPEROR

MERCHANT

TAILOR

FARMER

SCHOLAR

COMMON COMRADES
NERI & HU 2012

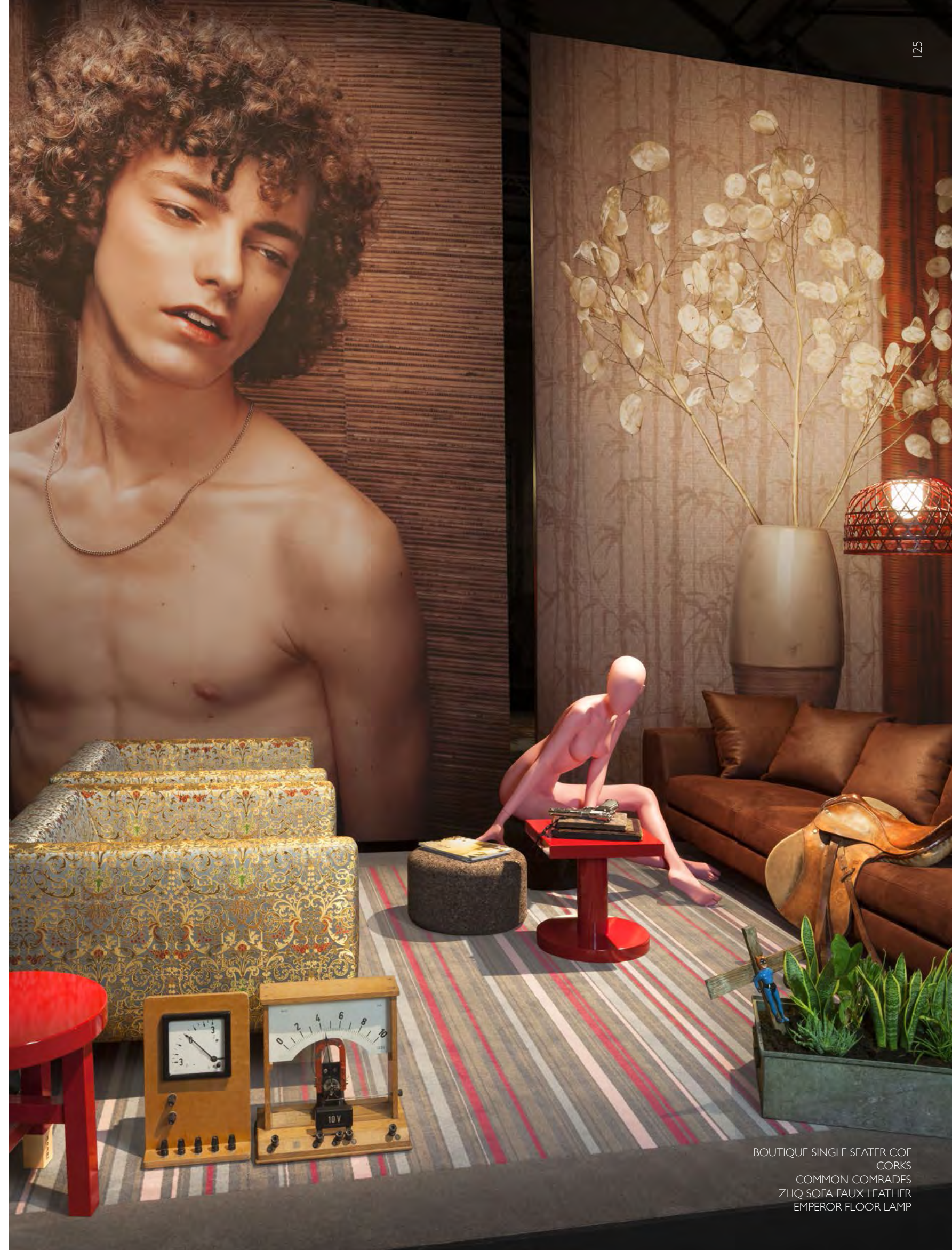

BOUTIQUE SINGLE SEATER COF
CORKS
COMMON COMRADES
ZLIQ SOFA FAUX LEATHER
EMPEROR FLOOR LAMP



HERACLEUM THE BIG O
 HERACLEUM II SMALL
 CONTAINER NEW ANTIQUESTABLE & STOOLS
 ALTDEUTSCHE CLOCK
 BIG BOLD
 COMMON COMRADES
 CLOUD SOFA



Altdeutsche Cabinet
 STUDIO JOB 2011

Inspired by the forgotten atmospheres & decorative character of antique Frankish furniture, Studio Job translate the old German hand-painted pieces into playful and happy designs for today's interiors. The solid pine wood becomes the canvas for an intricate, hand-finished study of man's double nature. On the one hand the worker bee, who needs the aid of tools and machines to produce efficiently, and on the other hand the philosopher, who constantly searches for meaning inside himself and in the world around him. Machines, nature, philosophy, life & death smoothly converge in a network of symbolic images, ultimately creating a tightly knit pattern that reproduces the colourful, chaotic and mysterious nature of life.



DETAIL ALTDEUTSCHE CHES



ALTDEUTSCHE CABINET
SET UP SHADES
BOUTIQUE DELFT BLUE JUMPER



SMOKE DINING ARMCHAIR
MAARTEN BAAS 2010

From the very beginning fire has inspired people with its warm glow and almost living motion, generating fascination and fear, comfort and warmth, passion and pain. It has been associated with emotions, personalities, love and has become part of the language of literature and of the vocabulary & gestures of our daily life.

Maarten Baas interpreted his fascination for the element fire with a groundbreaking approach. With the innovative idea of creating furniture furnished with fire. Capturing the burning flames into the solidity of wood. More practically, in the production process wooden pieces of furniture are set to fire and burned. When they become completely black the fire is extinguished and the piece of burned furniture are impregnated with resin to capture the beauty of burned wood.

Just like the Phoenix, the Smoke Chairs are reborn from their ashes, gaining new vitality and beauty in a very unusual way.



CLOUD SOFA
FAROOO
PAPER CHANDELIER L
PAPER SCREEN RAL



NON RANDOM
BERTJAN POT 2007



MASK LAMP
CORK
DELFT BLUE NO.92
DELFT BLUE NO.8



CARBON CHAIR
WOOD
MIYAKE 60



CARBON CHAIR
BERTJAN POT & MARCEL WANDERS 2004



JUUYO
EMPEROR FLOOR LAMP
PAPER TABLE RAL
CARBON CHAIR
PAPER BUFFET RAL
CORKS



RANDOM LIGHT LED
BERTJAN POT 2010



ZLIQ SOFA OLD BLUE
COMMON COMRADES
DOUBLE ROUND LIGHT
FRINGE
CLUSTERLAMP



EXTENSION CHAIR
TWO TOPS SECRETARY
EMPEROR TABLE LAMP



EXTENSION CHAIR
SJOERD VROONLAND 2010

The 'extension' chair is a translation of how a chair is used. Vroonland draws on the manners and customs of how we use a chair, transforming it into a coat hanger seat. What Vroonland intrigues is that technology, craftsmanship, storytelling and the actual physical contact all comes together in this one design: a chair.



CONSTRUCTION LAMP
CANVAS SOFA
PAPER SCREEN RAL
ELEMENTS 003
HERACLEUM II



DEAR INGO
RON GILAD 2003
Ron Gilad's hybrid objects combine material with aesthetic play; they sit on the fat delicious line between the abstract and the functional.
Direct the spots in the most functional crooked way or find your optimum balance.



Smoker Man based on the Smoke concept by Maarten Baas, concept & photography by Marcel Wanders & Erwin Olaf



COMMON COMRADES
 ZLIQ SOFA
 EMPEROR FLOOR LAMP
 RANDOM LIGHT
 DELFT BLUE NO. 6

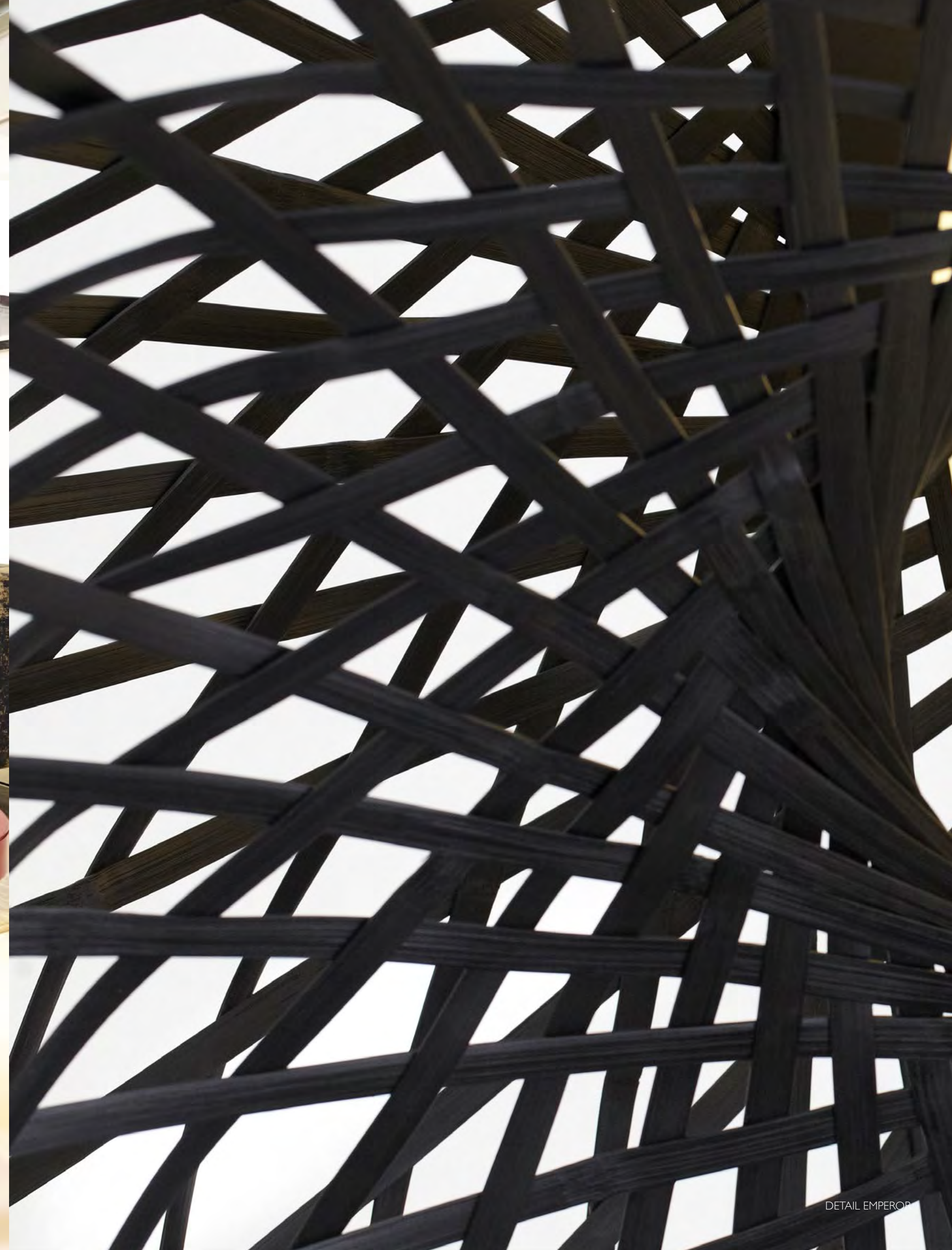

DETAIL EMPEROR



PAPER CABINET RAL
CHESS TABLE
RANDOM LIGHT



RABBIT LAMP

FRONT 2006

The Rabbit Lamp is one of a three piece collection of animal furniture which also includes a life-sized Horse Lamp and Pig Table. A perfect guest for a Mad Hatters tea party.



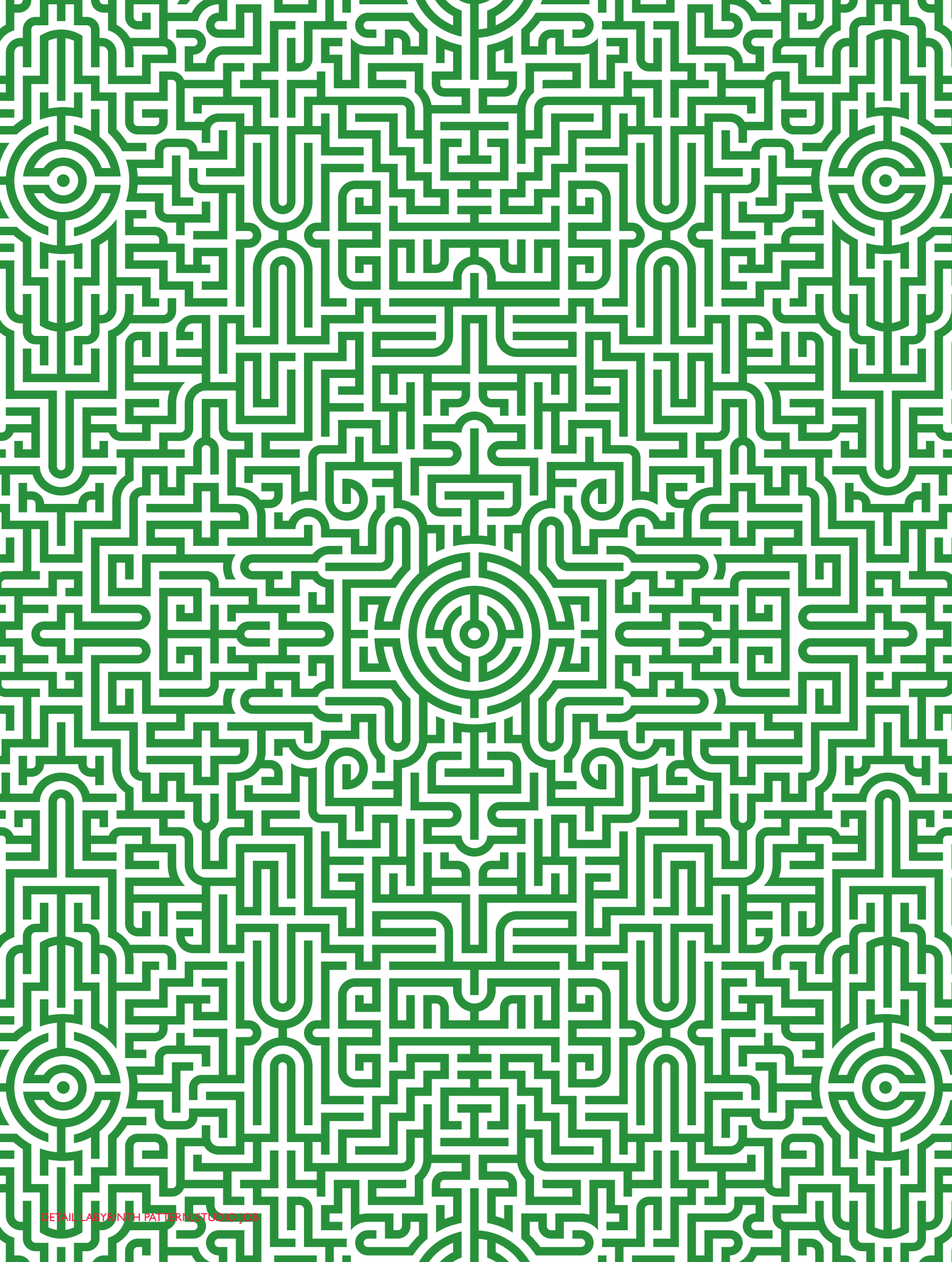



DEAR INGO
LABYRINTH CHAIR-ORIGINAL
RAIMOND
BOTTONI
LOLITA FLOOR LAMP



VALENTINE FLAT
MARCEL WANDERS 2012

"A magic mirror and the power of crystals transform a simple shell into an endless light bouquet of flowers" Marcel Wanders

After the sparkling excitement of a first date, with its fresh expectations and blossoming bouquet of spring feelings, Valentine slips out of his shiny black outfit and surprises us by wearing a fine golden ring. This unexpected gift bears promises of glorious moments to come... With the warm glow of his florid heart & the sophisticated slenderness of his golden gear, he has become a true knight in shining armor.
(available in a golden and a chrome version)

Love at first sight blooms and flourishes into an enchanted garden embraced by a bright ray of sun!





V.I.P. CHAIR
MARCEL WANDERS 2000



CHESS TABLE



THE KILLING OF THE PIGGY BANK
 SMOKE CHAIR
 CANVAS SOFA
 CONSTRUCTION LAMP



SMOKE CHAIR
 MAARTEN BAAS 2002
 Furniture finished with fire. The beauty and character of burnt wood is now captured in a long lasting material, creating the strange sensation of burnt furniture.

VALENTINE
MARCEL WANDERS 2011

"A magic mirror and the power of crystals transform a simple shell into an endless light bouquet of flowers", Marcel Wanders

Valentine's shiny, refined black, white, gold & chrome shell encloses and frames a meadow of light and sparkling glamour. With the style of a precious jewel, Valentine is designed to guard his heart of crystallized flowers, frosted in time. A treasure as perfect and untouchable as lovers' memories. As light and revealing as a first date. As exciting as the initial glimpse of a carefully wrapped gift.



with valentine it's love at first sight!



CANVAS SOFA
CONSTRUCTION LAMP



ELEMENTS 007
ELEMENTS 002
CANVAS SOFA
HERITAGE PILLOWS
BUCKET FLOOR LAMP



CONTAINER TABLE NEW ANTIQUES
 CONTAINER STOOL NEW ANTIQUES
 PAPER TABLE LAMP RAL



PAPER CABINET RAL
 STUDIO JOB 2012

moooi
design: Studio Job



PAPER TABLE LAMP
STUDIO JOB 2005
A sturdy structure wrapped in the visual softness and innocence of paper.



PAPER SIDE TABLE RAL
BIG BOLD
ZLIQ ISLAND
CONSTRUCTION LAMP
HERACLEUM THE BIG O



BUCKET SUSPENDED DETAIL



HERACLEUM II
BOTTONI SLIM SINGLE SEATER
CORK



ELEMENTS 007
EMPEROR TABLE LAMP
BART SOFA
ELEMENTS 003
PAPER FLOOR LAMP

URBANHIKE TABLE
MARCEL WANDERS 2012

The Urbanhike Table by Marcel Wanders is a symbol of Moooi's journey to reach the highest peaks of quality, innovation and style by spreading its designs to the most significant, beautiful cities in the world. Just like the original Alpine mountaineers used to do after climbing a summit, Moooi decorates its hiking cane with tags from all the metropolises that it conquered during its extensive travels. The Urbanhike Table is a playful reminder of the cosmopolitan heart and urban character of Moooi's designs!





BART SOFA
DANDELION
URBANHIKE
ELEMENTS_002
BART ARMCHAIR
RANDOM LIGHT



SMOKE DINING CHAIR
MAARTEN BAAS 2002

**DANDELION**

RICHARD HUTTEN 2004

True to its name Dandelion was initially inspired by the plant that creates the famous and poetic 'dandelion snow' of fuzzy, cotton-like seeds when a gush of wind blow on it. The lamp transmits an explosive feeling of energy in motion, reaching towards us from its centre. Striking and pure self-generate energy to lighten up and blow away the heaviness of everyday life.

DANDELION IS TRULY A BREATH OF FRESH AIR.



ALTDEUTSCHE CHEST
DANDELION FLOOR LAMP



Chess Table by Front, concept & photography by Marcel Wanders & Erwin Olaf

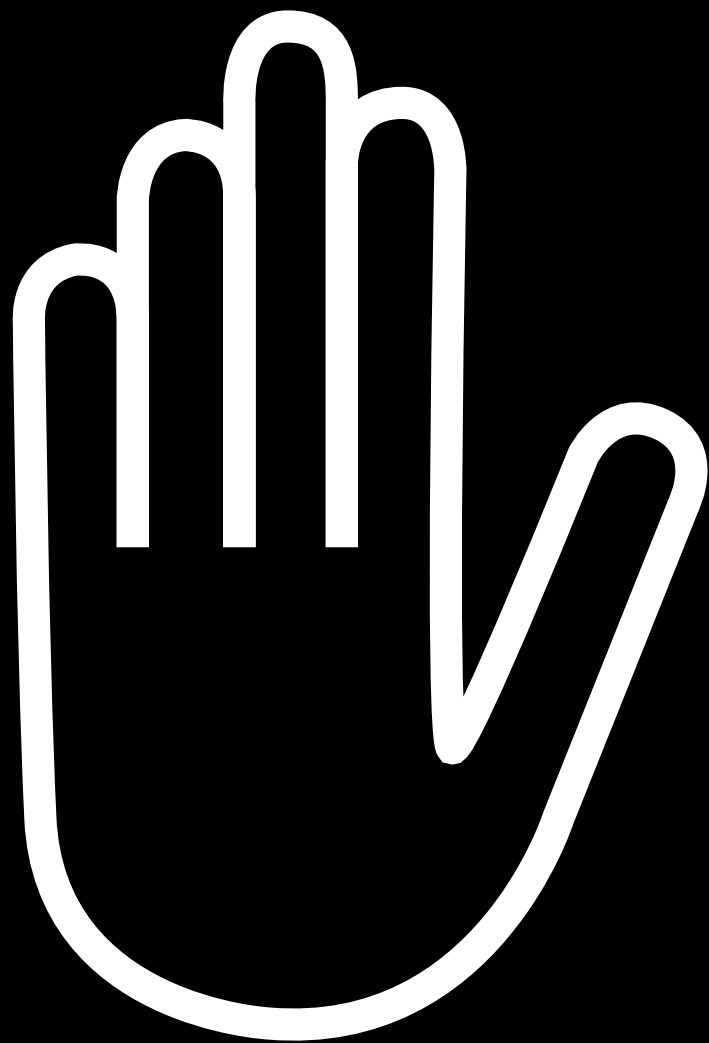

STOP THE BORING BUSINESS!



BRAVE NEW WORLD & BRAVE NEW WORLD XL

FRESH WEST, 2008
material: oak frame and cast iron balancing weights

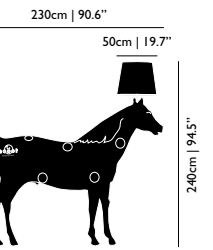
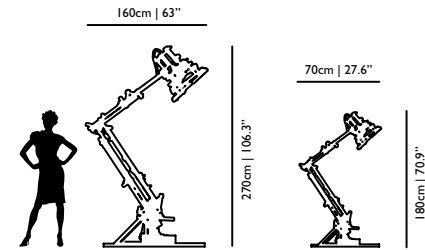

HORSE LAMP

FRONT, 2006
material: PVC/viscose laminate shade, a metal frame structure and polyester
colour: black

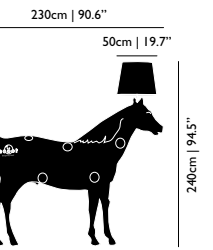

BUCKET FLOOR LAMP

STUDIO JOB, 2012
material: wood and cardboard, finished with paper and polyurethane (PU) lacquer; solid oak, gold plated steel, porcelain handle
colour: solid oak, grey shade

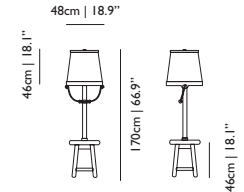

LIGHT SHADE SHADE FLOOR LAMP

JURGEN BEY (DROOG DESIGN), 1999
material: semi-transparent mirror film shade, metal frame structure and chrome base
colour: semi-transparent mirror

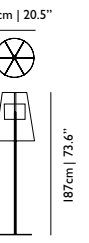

CONSTRUCTION LAMP S, M & L

JOOST VAN BLEISWIJK, 2012
material: die cast powdercoated aluminium, wooden version with wood slats
colour: matt black & white/wood

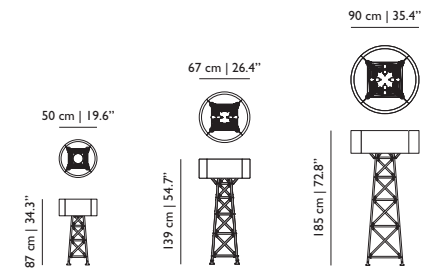

LOLITA FLOOR LAMP

NIKA ZUPANC, 2008
material: injection moulded ABS shade
colour: black, white, pink & grey

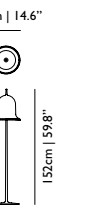

DANDELION FLOOR LAMP

RICHARD HUTTEN, 2004
material: laser-cut powder-coated aluminium
colour: white RAL 9016

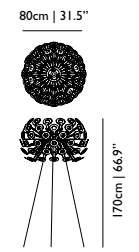

MIYAKE I10

ARIHIRO MIYAKE, 2009
material: cast metal head, aluminium tube, concrete base
colour: white RAL 9016, white concrete

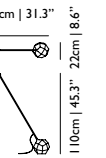

DOUBLE SHADE

MARCEL WANDERS, 1998
material: PVC/viscose laminate on metal structure
colour: black & white

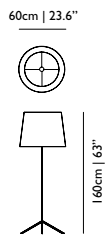

**PAPER FLOOR LAMP
WHITE, RAL & PATCHWORK**

STUDIO JOB, 2005 & 2012
material: wood and cardboard, finished with paper and polyurethane (PU) lacquer
colour: white, RAL 1004, RAL 1013, RAL 1023, RAL 1027, RAL 2000, RAL 2002, RAL 2004, RAL 3012, RAL 3015, RAL 5003, RAL 5008, RAL 5024, RAL 6010, RAL 6021, RAL 7001, RAL 7011, RAL 7035, RAL 7044, RAL 8001, RAL 8014, RAL 8016, RAL 9005, RAL 9010

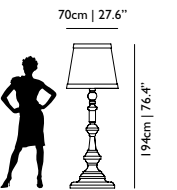

EMPEROR FLOOR LAMP

NERI & HU, 2009
material: bamboo rattan cage shade and glass diffuser; Zamac base with steel frame
colour: black RAL 9005 & red RAL 3004

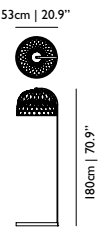

RANDOM LIGHT LED FLOOR LAMP S & M

BERTJAN POT, 2001
material: fibreglass soaked in epoxy resin, matt chromed steel base (white), semi gloss black powder, coated base (black), matt aluminium heat sink and opal glass
colour: black & white

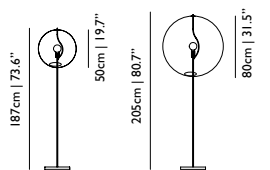

SET UP SHADES 5, 6 & 7

MARCEL WANDERS, 1989
material: PVC/viscose laminate on a metal structure
colour: white

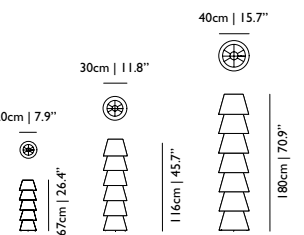

FAROO S, M & L

MARCEL WANDERS, 2012
material: base: fibreglass, shade: PVC/viscose laminate on a metal structure
colour: black, red & white

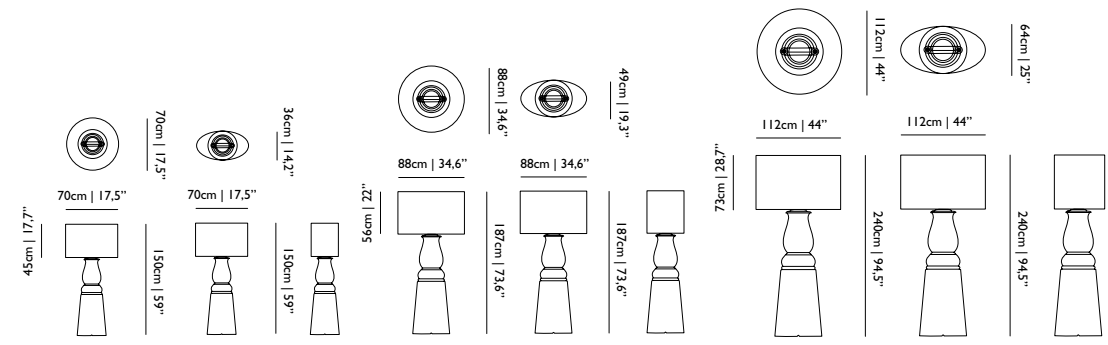

TRIX

MARCEL WANDERS, 1998
material: PVC/viscose laminate on a metal structure
colour: white

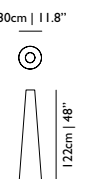



BELL LAMP & BELL LAMP SMALL

MARCEL WANDERS, 2012

material: glass shade with porcelain bow
 colour: white or gold bow, transparent, white, amber, green & smoke shade
 opal glass diffuser

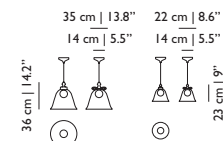

BUCKET LAMP

STUDIO JOB, 2012

material: wood and cardboard, finished with paper and polyurethane (PU) lacquer,
 solid oak, gold plated steel, porcelain handle
 colour: grey shade

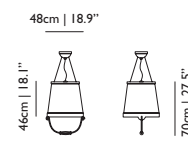

CLUSTERLAMP

JOEL DEGERMARK, 2004

material: Polybutylene Terephthalate (PBT)
 colour: white

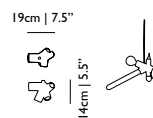

DANDELION

RICHARD HUTTEN, 2004

material: laser-cut powder-coated aluminium
 colour: white RAL 9016



DEAR INGO

RON GILAD, 2003

material: powder coated steel
 colour: black & white

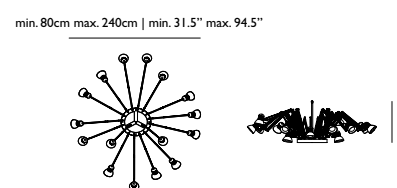

EMPEROR

NERI & HU, 2009

material: bamboo rattan cage shade and glass diffuser
 colour: black RAL 9005 & red RAL 3004

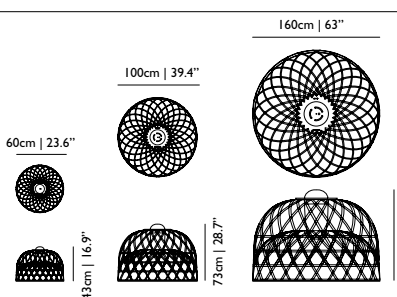

HANG

MARCEL WANDERS, 1998

material: PVC/viscose laminate shade and a metal frame structure
 colour: black & white

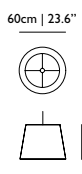

HERACLEUM II

BERTJAN POT

POWERED THROUGH ELECTROSANDWICH® BY MARCEL WANDERS, 2010
 material: metal wire frame, polycarbonate lenses ultra thin suspension wire
 colour: copper & nickel

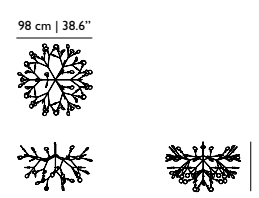

HERACLEUM II SMALL

BERTJAN POT

POWERED THROUGH ELECTROSANDWICH® BY MARCEL WANDERS, 2012
 material: metal wire frame, polycarbonate lenses ultra thin suspension wire
 colour: copper & nickel



HERACLEUM THE BIG O

BERTJAN POT

POWERED THROUGH ELECTROSANDWICH® BY MARCEL WANDERS, 2012
 material: metal wire frame, polycarbonate lenses ultra thin suspension wire
 colour: copper & nickel

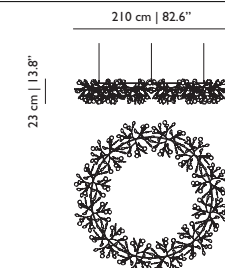

JUUYO

PEACH FLOWERS & KOI CARP TATTOO

LORENZA BOZZOLI, 2012

material: glazed ceramics with decal inside
 colour: white

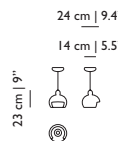

KROON 7 & 11

ZMIK, 2012

material: anodized aluminium and borosilicate glass tubes
 colour: matt black

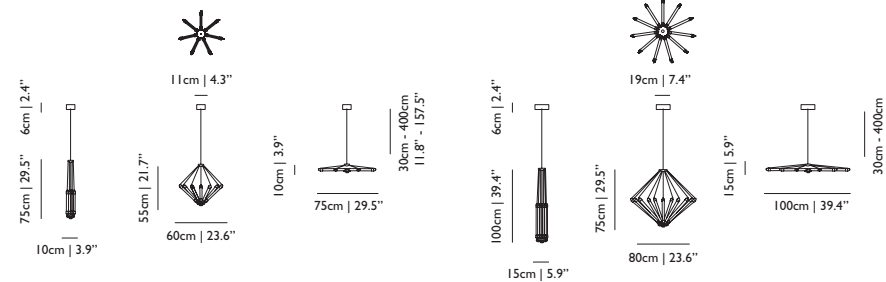

LIGHT SHADE SHADE Ø47, Ø70 & Ø95

JURGEN BEY (DROOG DESIGN), 1999

material: semi-transparent mirror film shade, metal frame structure
 colour: semi-transparent mirror

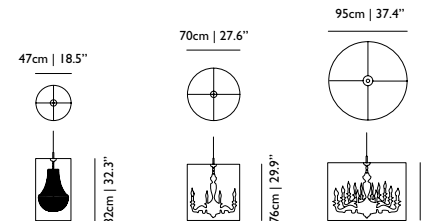

LOLITA

NIKA ZUPANC, 2008

material: injection moulded ABS shade
 colour: black, white, pink & grey

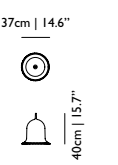

LONG LIGHT & OVAL LIGHT

MARCEL WANDERS, 1999

material: PVC/viscose laminate and a metal frame structure
 colour: black & white

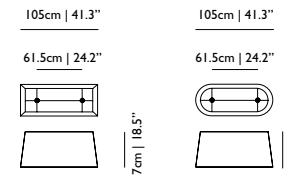

MISTRAL

MOOOI WORKS, 2010

material: chromed body, wooden blades, PVC/viscose laminate,
 intricate glass diffuser, reversible wind direction
 colour: dark brown, white & off white

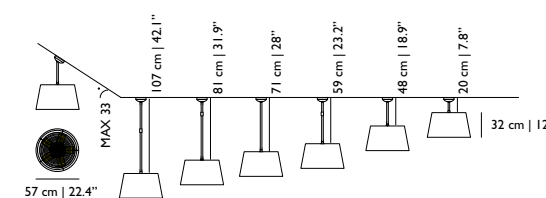

NON RANDOM Ø48 & Ø71

BERTJAN POT, 2007

material: fibreglass soaked in epoxy resin, powder coated aluminium cap,
 reflector: shiny anodized aluminium
 colour: black & white

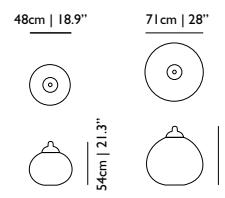



PAPER CHANDELIER L & XL WHITE, RAL & PATCHWORK

STUDIO JOB, 2005 & 2012

material: wood and cardboard, finished with paper and polyurethane (PU) lacquer
colour: white, RAL 1004, RAL 1013, RAL 1023, RAL 1027, RAL 2000, RAL 2002, RAL 2004, RAL 3012, RAL 3015, RAL 5003, RAL 5008, RAL 5024, RAL 6010, RAL 6021, RAL 7001, RAL 7011, RAL 7035, RAL 7044, RAL 8001, RAL 8014, RAL 8016, RAL 9005, RAL 9010

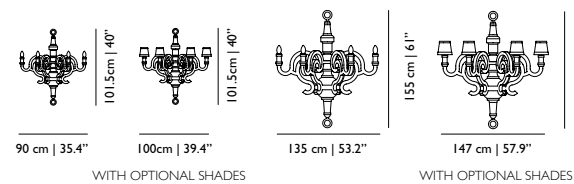

RAIMOND DOME 79

RAIMOND PUTS, 2012 | REALISATION BY OX-ID
material: stainless 'spring steel' and PMMA

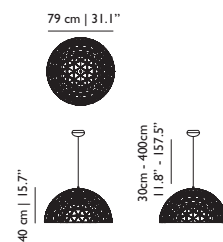

RAIMOND R43, R61, R89

RAIMOND PUTS, 2012 | REALISATION BY OX-ID
material: stainless 'spring steel'

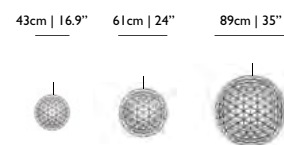

RAIMOND ZAFU

RAIMOND PUTS, 2012 | REALISATION BY OX-ID
material: stainless 'spring steel'

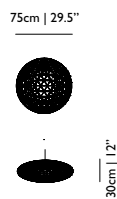

RAIMOND R127, R163 & R199

RAIMOND PUTS, 2012 | REALISATION BY OX-ID
material: stainless 'spring steel' and PMMA

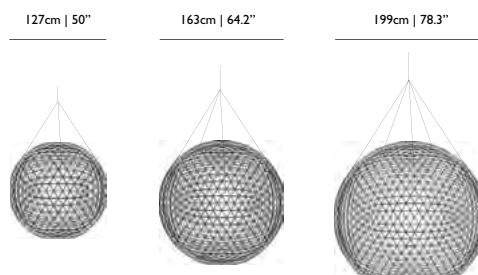

RANDOM LIGHT & RANDOM LIGHT LED S, M & L

BERTJAN POT 2001
material: fibreglass soaked in epoxy resin, chromed steel pendant
colour: black & white

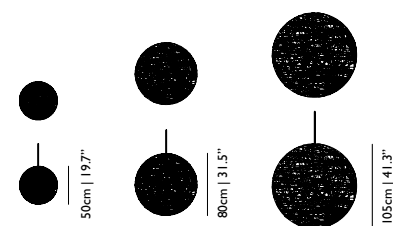

ROUND & SQUARE BOON

PIET BOON, 2002
material: PVC/viscose laminate on metal frame, chromed steel pendant,
diffuser: PVC/viscose laminate
colour: black & white

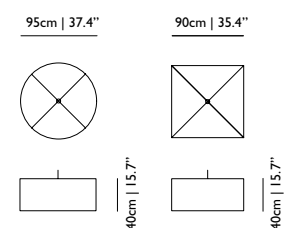

ROUND & SQUARE LIGHT

MARCEL WANDERS, 1998
material: PVC/viscose laminate and a metal frame structure, chromed steel pendant
colour: black & white

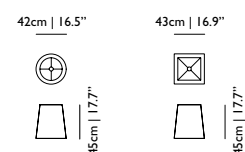

SMOKE CHANDELIER

MAARTEN BAAS, 2002
material: burnt wood finished with epoxy
colour: black

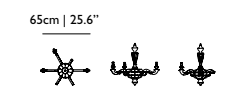

TUB LAMP

STUDIO JOB, 2012
material: wood and cardboard, finished with paper and polyurethane (PU) lacquer,
gold plated steel, porcelain handle
colour: grey shade

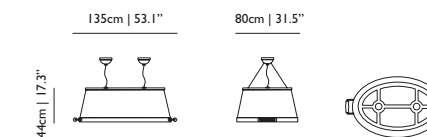

TUBE

MARCEL WANDERS, 1998
material: PVC/viscose laminate and a metal frame structure, chromed steel pendant
colour: white

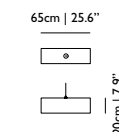

VALENTINE & BABY VALENTINE

MARCEL WANDERS, 2011
material: crystal clear blown glass with chromed, gold plated or lacquered shade,
transparent cord and steel cable
colour: black, chrome, white & gold

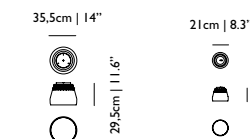

VALENTINE FLAT

MARCEL WANDERS, 2012
material: crystal clear blown glass in chromed or gold plated body
colour: chrome & gold

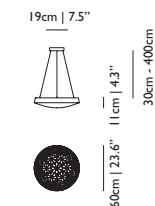
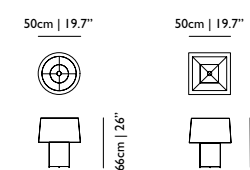

TABLE LAMPS



DOUBLE ROUND & DOUBLE SQUARE LIGHT

MARCEL WANDERS, 1999
material: PVC/viscose laminate on metal structure
colour: black & white



EMPEROR TABLE LAMP

NERI & HU, 2009
material: bamboo rattan cage shade and glass diffuser, Zamac base with steel frame
colour: black RAL 9005 & red RAL 3004

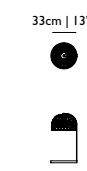

KAIPO TOO

EDWARD VAN VLIET, 2012
material: mouth blown glass
colour: smoke, red-gradient, white-gradient



LOLITA TABLE LAMP

NIKA ZUPANC, 2008
material: injection moulded ABS shade
colour: black, grey, pink & white

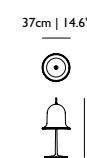



MASK LAMP

STEFANO GIOVANNONI, 2010
 material: 3D pressed oak veneer; chrome base
 colour: black stained oak, natural oak, white wash oak

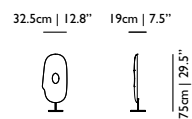

CORKS

JASPER MORRISON, 2002
 material: 100% cork
 colour: brown

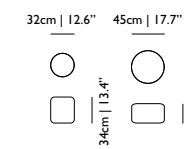

MIYAKE 60

ARIHIRO MIYAKE, 2009
 material: cast metal base & head, aluminum tube
 colour: white RAL 9016

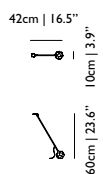

CROCHET TABLE

MARCEL WANDERS, 2001
 material: handmade crochet cotton & epoxy resin
 colour: white

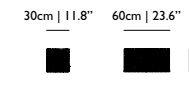

PAPER TABLE LAMP
 WHITE, RAL & PATCHWORK

STUDIO JOB, 2005 & 2012
 material: wood and cardboard, finished with paper and polyurethane (PU) lacquer
 colour: white, RAL 1004, RAL 1013, RAL 1023, RAL 1027, RAL 2000, RAL 2002, RAL 2004, RAL 3012, RAL 3015, RAL 5003, RAL 5008, RAL 5024, RAL 6010, RAL 6021, RAL 7001, RAL 7011, RAL 7035, RAL 7044, RAL 8001, RAL 8014, RAL 8016, RAL 9005, RAL 9010



PAPER SIDE TABLE
 WHITE, RAL & PATCHWORK

STUDIO JOB, 2005 & 2012
 material: wood and cardboard, finished with paper and polyurethane (PU) lacquer
 colour: white, RAL 1004, RAL 1013, RAL 1023, RAL 1027, RAL 2000, RAL 2002, RAL 2004, RAL 3012, RAL 3015, RAL 5003, RAL 5008, RAL 5024, RAL 6010, RAL 6021, RAL 7001, RAL 7011, RAL 7035, RAL 7044, RAL 8001, RAL 8014, RAL 8016, RAL 9005, RAL 9010
 patchwork #11: RAL 3015

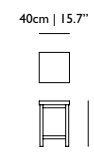

RABBIT LAMP

FRONT, 2006
 material: PVC/viscose laminate shade, a metal frame structure and polyester Rabbit
 colour: black



PIG TABLE

FRONT, 2006
 material: Pig; polyester; top: acrylonitrile butadiene styrene (ABS)
 colour: black
 indoor use only

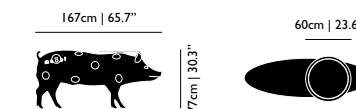

SECRETARY



TWO TOPS SECRETARY

MARCEL WANDERS, 2010
 material: solid oak frame with a veneer top
 colour: natural lacquer, black stained, wenge stained, white wash, red RAL 3020, orange RAL 2004, black RAL 9005, white RAL 9016
 additional: Two Tops box is available to purchase separately

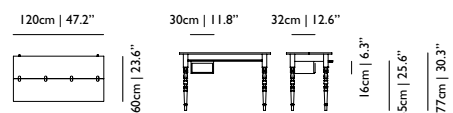

URBANHIKE

MARCEL WANDERS, 2012
 material: chromed steel, decalized aluminum wood transfer
 colour: walnut decal, chrome
 there are seven different badges included with the table, you can paste them yourself and give the final and personal touch to the Urbanhike table

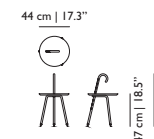

TABLES



WOOD

MARCEL WANDERS, 2010
 material: solid beech frame, 3D pressed oak veneer top
 colour: black stained



5 O'CLOCK TABLE

NIKA ZUPANC, 2010
 material: Solid beech frame, MDF top, upholstery composition: 88% PVC - compound, 10% PES - fabric, 2% Nano - hightech - compound
 colour: black stained

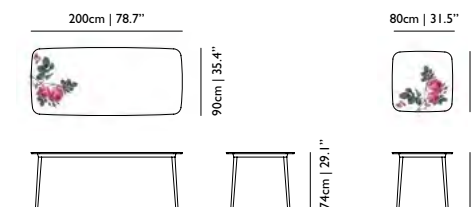

SIDE TABLES



CHESS TABLE

FRONT, 2009
 material: internal steel frame, legs are made of solid wood, table top is made of MDF.
 high gloss lacquer
 colour: black & white

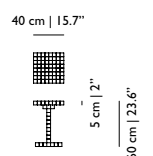

PAPER TABLE
 WHITE, RAL & PATCHWORK

STUDIO JOB, 2005 & 2012
 material: wood and cardboard, finished with paper, polyurethane (PU) and wood veneer
 colour: white, RAL 1004, RAL 1013, RAL 1023, RAL 1027, RAL 2000, RAL 2002, RAL 2004, RAL 3012, RAL 3015, RAL 5003, RAL 5008, RAL 5024, RAL 6010, RAL 6021, RAL 7001, RAL 7011, RAL 7035, RAL 7044, RAL 8001, RAL 8014, RAL 8016, RAL 9005, RAL 9010

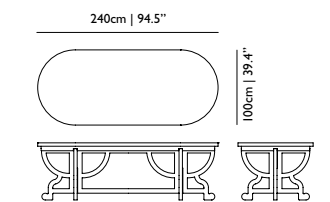

COMMON COMRADES

NERI & HU, 2012
 material: solid birch
 colour: red RAL 3003
 six different models available

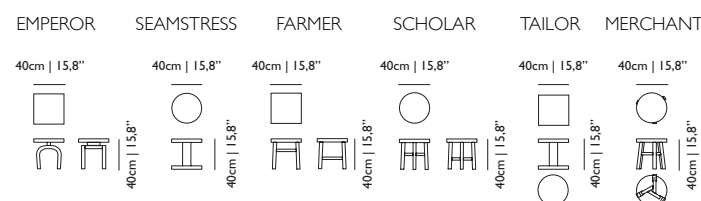

TWO TOPS TABLE

MARCEL WANDERS 2004
 material: solid oak frame with a veneer top
 colour: natural lacquer, black stained, wenge stained, white wash, red RAL 3020, orange RAL 2004, black RAL 9005, white RAL 9016

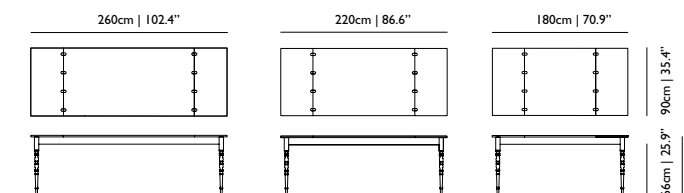

<p>7030 7132</p>	<p>10030 10632</p>	<p>2X 7030 2X 7132</p>	<p>7043 7143</p>	<p>7056 7156</p>
<p>HPL</p> <p>Ø70 70x70 80x80 Ø90 90x90</p>	<p>Ø70 70x70 80x80</p>	<p>180x80</p>	<p>Ø120 120x120 Ø140</p>	<p>Ø160 160x160 Ø180</p>
<p>LPL</p> <p>Ø70 70x70 80x80 Ø90 90x90</p>	<p>Ø70 70x70 80x80</p>	<p>180x80</p>	<p>Ø120 120x120 Ø140</p>	<p>Ø160 160x160</p>
<p>WOOD</p> <p>Ø70 70x70 80x80 Ø90 90x90</p>	<p>Ø70 70x70 80x80</p>	<p>180x80</p>	<p>Ø120 120x120 Ø140</p>	<p>Ø160 160x160 Ø180</p>
<p>WOOD</p> <p>Ø70 70x70 80x80 Ø90 90x90</p>	<p>Ø70 70x70 80x80</p>	<p>180x80</p>	<p>Ø120 120x120 Ø140</p>	<p>Ø160 160x160 Ø180</p>



CONTAINER TOP HPL

material: HPL top: a flat panel based on thermosetting resins, homogeneously reinforced with woodfibres and manufactured under high pressure and at high temperatures.
thickness 12mm | 0.5"
colour: black, white, wenge & light grey
suitable for outside use



CONTAINER TOP LPL

material: a flat panel based on thermosetting resins, which is pressed under low pressure
thickness 25mm | 1"
colour: black, white, wenge & light grey



CONTAINER TOP WOOD

material: oak veneer
thickness 40mm | 1.6"
colour: black RAL9005, white RAL9016, red RAL3020, orange RAL2004
wenge, black stained, white wash, natural lacquered

CONTAINER FOOT

MARCEL WANDERS, 2002
material: PE
colour: black & white
the feet can be filled with water or sand to create extra stability

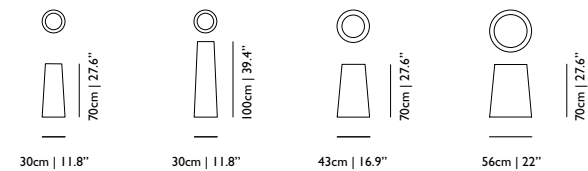

CONTAINER FOOT NEW ANTIQUES

MARCEL WANDERS, 2010
material: PE
colour: black, white, brown & grey
the feet can be filled with water or sand to create extra stability

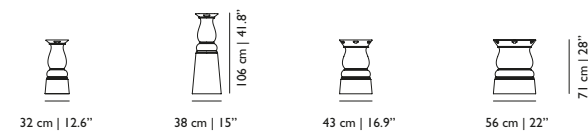



ALTDEUTSCHE CLOCK

STUDIO JOB, 2011
 material: solid pine and pine veneer; stained in white
 colour: stained white, hand painted art work
 handmade quality spring driven eight day movement, use the included custom Studio Job key to wind up, hourly clock bell chime

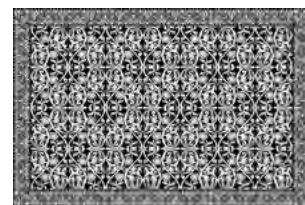
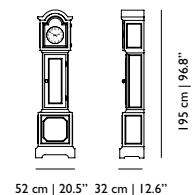

CARPET NO. 06
 FOR CARPET NO. 03, 07, 11 SEE WWW.MOOOI.COM

MARCEL WANDERS, 2005
 material: printed nylon threads
 colour: black & white
 size: 200 x 300cm | 78.7" x 118.1"



BIG BEN

MARCEL WANDERS, 2011
 material: fibreglass with powder coated aluminum hands
 colour: white dial, black rim & hands

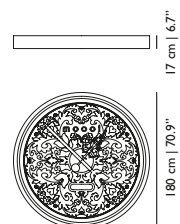

CARPET NO. 14
 FIRMSHIP

STUDIO JOB, 2010
 material: printed nylon threads
 colour: grey & white
 size: Ø350cm | 137.8"



BLOW AWAY VASE

FRONT, 2008
 material: porcelain, produced by Royal Delft
 colour: white & blue

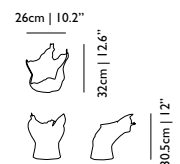

CARPET NO. 15
 FATA MORGANA TJ

MARCEL WANDERS, 2010
 material: printed nylon threads
 colour: various
 size: Ø350cm | 137.8"



BIG BOLD

RODERICK VOS, 2005
 material: powder coated steel
 colour: black

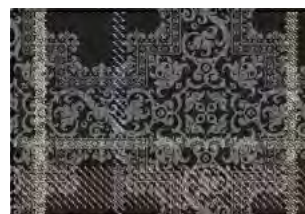
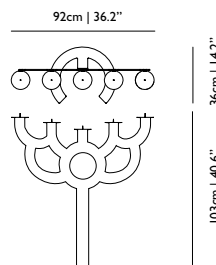

CARPET NO. 16
 FATA MORGANA TJ

MARCEL WANDERS, 2010
 material: printed nylon threads
 colour: various
 size: 300 x 200cm | 118.1"



MENORAH BOLD

RODERICK VOS, 2005
 material: powder coated steel
 colour: black

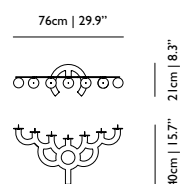

CONTAINER BOWL

MARCEL WANDERS, 2007
 material: PE
 colour: black & white
 indoor and outdoor use

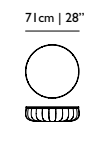

LITTLE BOLD

RODERICK VOS, 2005
 material: powder coated steel
 colour: black

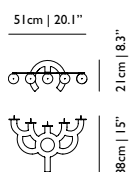

CONTAINER BOWL BASE

MARCEL WANDERS, 2007
 material: PE
 colour: black & white
 indoor and outdoor use

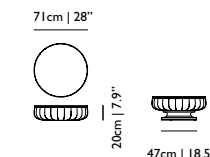

CARPET NO. 1

MARCEL WANDERS, 2005
 material: printed nylon threads
 colour: blue & white
 size: Ø240cm | 94.5"



CONTAINER BOWL TOP

MARCEL WANDERS, 2007
 material: PE
 colour: black & white
 indoor and outdoor use

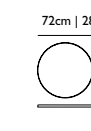

CARPET NO. 12

MARCEL WANDERS, 2005
 material: printed nylon threads
 colour: brown & white
 size: 250 x 250cm | 98.4" x 98.4"



CONTAINER BOWL + FOOT

MARCEL WANDERS, 2007
 material: PE
 colour: black & white
 indoor and outdoor use

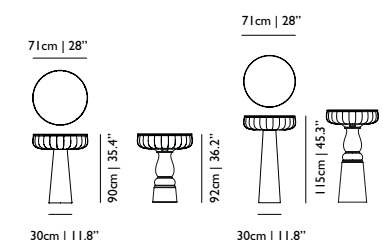



CONTAINER VASE + FOOT

MARCEL WANDERS, 2007
 material: PE
 colour: black & white
 indoor and outdoor use
 the feet can be filled with sand to create extra stability

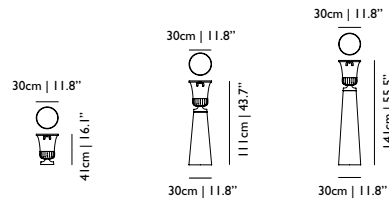

FRAME MIRROR

MARCEL WANDERS, 2005
 material: anodized aluminum, black MDF back panel and glass mirror
 colour: black anodized

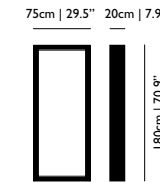

DELFT BLUE

MARCEL WANDERS, 2008
 material: porcelain, produced by Royal Delft
 colour: various

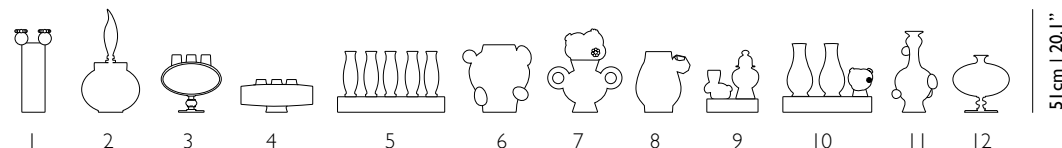

MING VASE

MARCEL WANDERS, 1997
 material: unglazed porcelain outside, white glazed inside
 colour: white



PAPER MIRROR

WHITE & RAL
 STUDIO JOB, 2005 & 2012
 material: wood and cardboard, finished with paper, polyurethane (PU) and wood veneer
 colour: white, RAL 1004, RAL 1013, RAL 1023, RAL 1027, RAL 2000, RAL 2002, RAL 2004, RAL 3012, RAL 3015, RAL 5003, RAL 5008, RAL 5024, RAL 6010, RAL 6021, RAL 7001, RAL 7011, RAL 7035, RAL 7044, RAL 8001, RAL 8014, RAL 8016, RAL 9005, RAL 9010

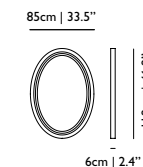

EGG VASE

MARCEL WANDERS 1997
 material: unglazed porcelain outside, white glazed inside
 colour: white



PAPER SCREEN

WHITE, RAL & PATCHWORK
 STUDIO JOB, 2005 & 2012
 material: wood and cardboard, finished with paper, polyurethane (PU) and wood veneer
 colour: white, RAL 1004, RAL 1013, RAL 1023, RAL 1027, RAL 2000, RAL 2002, RAL 2004, RAL 3012, RAL 3015, RAL 5003, RAL 5008, RAL 5024, RAL 6010, RAL 6021, RAL 7001, RAL 7011, RAL 7035, RAL 7044, RAL 8001, RAL 8014, RAL 8016, RAL 9005, RAL 9010 at more for extra length

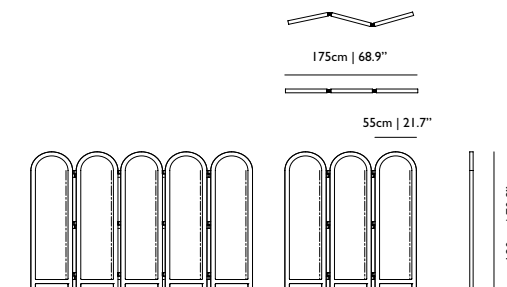

ELEMENTS

JAIME HAYON, 2007
 colour 002, 004 & 007: black RAL 9005, white RAL 9016, warm grey RAL 7044 & ocean blue RAL 5020
 material 002, 004 & 007: fibreglass (007 with glass top inlay) (004 with glass mirror)
 material 003: aluminium powder coated | colour 003: white RAL 9016
 material 005 & 006: expanded polypropylene (EPP), upholstered with Kvadrat Divina Melange
 colour 005 & 006: Kvadrat Divina Melange 120 (light grey), 180 (dark grey), 260 (light brown) & 681 (aubergine)
 material 001 & 006: solid wood
 colour tray 001 & 006: wenge, black & white

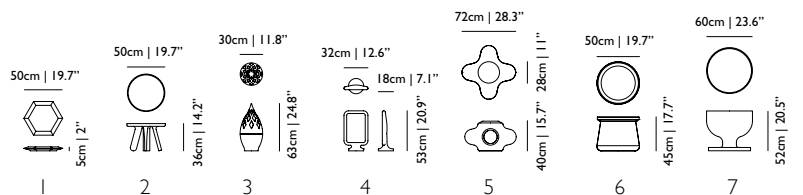

SPONGE VASE

MARCEL WANDERS, 1997
 material: unglazed porcelain outside, white glazed inside
 colour: white



THE KILLING OF THE PIGGY BANK

MARCEL WANDERS, 2009
 material: porcelain, produced by Royal Delft
 colour: white, blue & gold

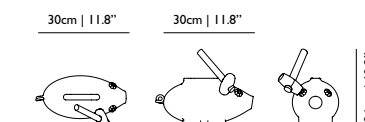

FOAM BOWL

MARCEL WANDERS, 1997
 material: porcelain
 colour: white

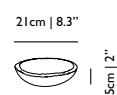

FRAME

MARCEL WANDERS, 2005
 material: extruded and anodized aluminum
 colour: black anodized
 connection set can be ordered to connect two frames

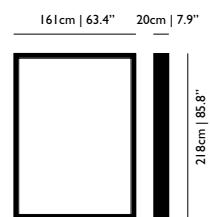

HERITAGE & OIL PILLOWS

MARCEL WANDERS, 2012
 material: Heritage: 78% cotton, 22% polyamide | Oil: 63% viscose, 28% cotton, 9% polyamide
 colour: Heritage: black & white | Oil: black, white & red



CARBON CHAIR

BERTJAN POT & MARCEL WANDERS, 2004
material: carbon fibre drained in epoxy resin
colour: black

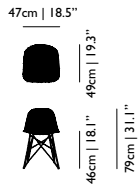

NEW ANTIQUES CONTAINER STOOL

MARCEL WANDERS, 2010
material: PE
colour: grey, black, brown & white



CONTAINER STOOL

MARCEL WANDERS, 2004
material: PE
colour: black & white

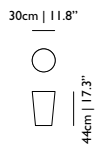

5 O'CLOCK CHAIR

NIKA ZUPANC, 2010
material: solid beech frame and skai leather upholstered seat and back
upholstering composition: 88% PVC-compound, 10% PES-fabric, 2% Nano-hightech-compound
colour: frame: black stained

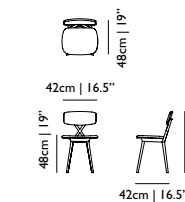

EXTENSION CHAIR

SJOERD VROONLAND, 2010
material: solid beech
colour: matt black
handbag hanger and standard cap included
optional: coat stand & card holder

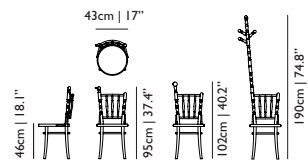

SMOKE DINING CHAIR

MAARTEN BAAS, 2002
material: smoked solid wood, epoxy resin; leather upholstery, naturally fire retardant
on fire retardant foam
colour: black
each piece may differ due to the process used for production

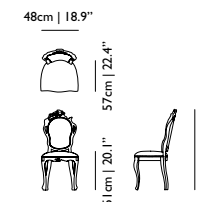

GOLDEN CHAIR

NIKA ZUPANC, 2011
material: synthetic leather; chromed steel frame
colour: gold

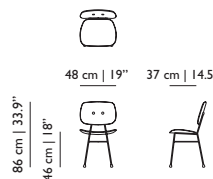

SMOKE DINING ARMCHAIR

MAARTEN BAAS, 2002
material: smoked solid wood, epoxy resin; leather upholstery, naturally fire retardant
on fire retardant foam
colour: black
each piece may differ due to the process used for production

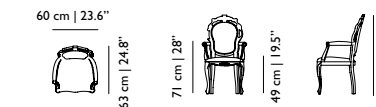

GOTHIC CHAIR

STUDIO JOB, 2010
material: PE, ABS buttons, felt feet
colour: light grey, dark grey, blue, brown, white, yellow, orange, pink, red and green
colour buttons: light grey, dark grey, blue, white, yellow, red and green
***please specify your button colour*

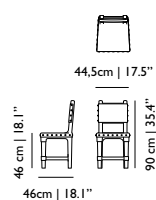

V.I.P. CHAIR

MARCEL WANDERS, 2000
material: fire retardant foam covered steel frame, nylon wheels suitable for different floortypes
colour: available in a variety of colours from the fabric collections: Kvadrat Divina, Divina Melange

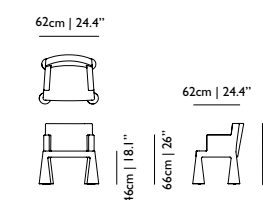

MONSTER BARSTOOL & BARSTOOL LOW

MARCEL WANDERS, 2010
material: fire retardant synthetic leather on foam upholstered steel frame
88% PVC - compound, 12% PES - fabric
colour: black
Monster Barstools are without embroidery

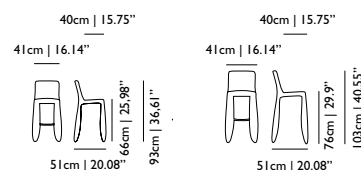

ARMCHAIRS



BART ARMCHAIR

MOOOI WORKS | BART SCHILDER, 2012
material: wooden frame covered in foam and dacron, the seat cushion is made in foam.
material upholstery: see page 205
colour: various, see page 204

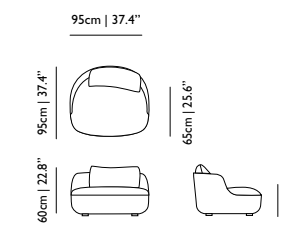

MONSTER CHAIR & MONSTER ARMCHAIR

MARCEL WANDERS, 2010
material: fire retardant synthetic leather on foam upholstered steel frame
88% PVC - compound, 12% PES - fabric
colour: black
optional: monster embroidery

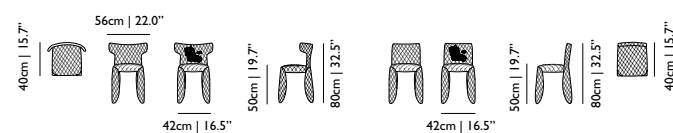

BART CANAPE ARMCHAIR

MOOOI WORKS | BART SCHILDER, 2012
material: wooden frame covered in foam and dacron, the seat cushion is made in foam.
material upholstery: see page 205
colour: various, see page 204

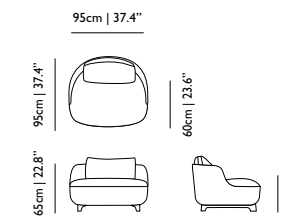

NEW ANTIQUES BARSTOOL & NEW ANTIQUES BARSTOOL LOW

MARCEL WANDERS, 2012
material: PE
colour: light grey, dark grey, blue, brown, white, yellow, orange, pink, red and green

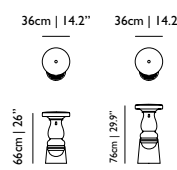

BOTTONI SINGLE SEATER

MARCEL WANDERS, 2002
material: multiple density foam on plywood frame, stainless steel feet.
colour: available in a variety of colours from the fabric collections: Kvadrat Divina, Divina Melange, Tonica, Hallingdal or your own (COF)

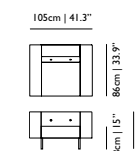

BOTTOMI SLIM SINGLE SEATER

MARCEL WANDERS, 2002
 material: multiple density foam on plywood frame, stainless steel feet.
 colour: available in a variety of colours from the fabric collections: Kvadrat Divina, Divina Melange, Tonica, Hallingdal or your own (COF)

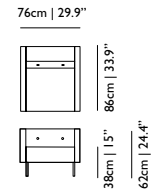
**BART XL SOFA**

MOOOIWORKS | BART SCHILDER, 2012
 material: wooden frame covered in foam and dacron, the seat cushion is made in foam.
 material upholstery: see page 205
 colour: various, see page 204

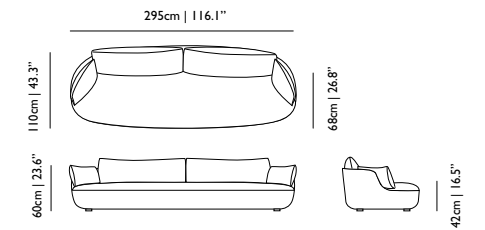
**BOUTIQUE SINGLE SEATER**

MARCEL WANDERS, 2005
 material: seater: steel base construction, CMHR foam upholstered,
 cover: fabric is teflon treated and has a fire retardant coating

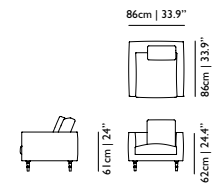
**BOTTOMI DOUBLE & TRIPLE SEATER**

MARCEL WANDERS, 2002
 material: multiple density foam on plywood frame, stainless steel feet.
 colour: available in a variety of colours from the fabric collections: Kvadrat Divina, Divina Melange, Tonica, Hallingdal or your own (COF)

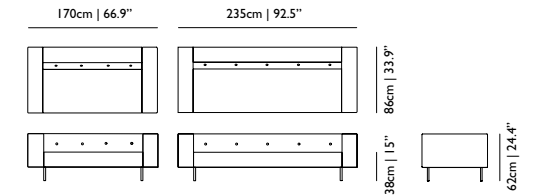
**BOUTIQUE FOOTSTOOL**

MARCEL WANDERS, 2005
 material: seater: steel base construction, CMHR foam upholstered,
 cover: fabric is teflon treated and has a fire retardant coating

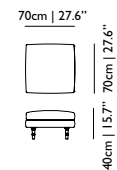
**BOTTOMI SHELF TRIPLE SEATER**

MARCEL WANDERS, 2002
 material: multiple density foam on plywood frame, stainless steel feet.
 colour: available in a variety of colours from the fabric collections: Kvadrat Divina, Divina Melange, Tonica, Hallingdal or your own (COF)

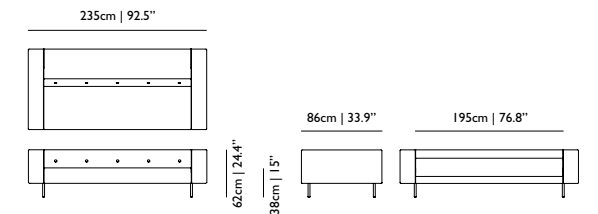
**LABYRINTH CHAIR**

STUDIO JOB, 2012
 material: wood frame, foam and dacron upholstered
 composition: 24% polyethyleen, 47% cotton, 29% linen
 colour: Insect: black & white, Original: white & green, Grey: white & grey

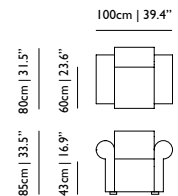
**BOTTOMI SLIM DOUBLE & TRIPLE SEATER**

MARCEL WANDERS, 2002
 material: multiple density foam on plywood frame, stainless steel feet.
 colour: available in a variety of colours from the fabric collections: Kvadrat Divina, Divina Melange, Tonica, Hallingdal or your own (COF)

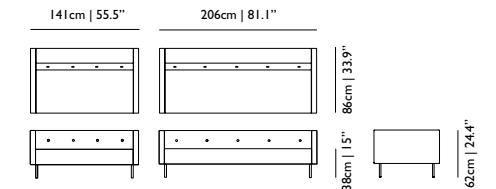
**SMOKE CHAIR**

MAARTEN BAAS, 2002
 material: wood frame, foam and dacron upholstered
 on fire retardant foam
 colour: black
 each piece may differ due to the process used for production

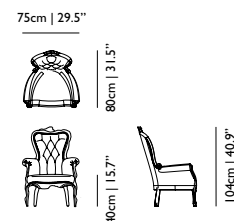
**BOUTIQUE DOUBLE & TRIPLE SEATER**

MARCEL WANDERS, 2005
 material: seater: steel base construction, CMHR foam upholstered,
 cover: fabric is teflon treated and has a fire retardant coating

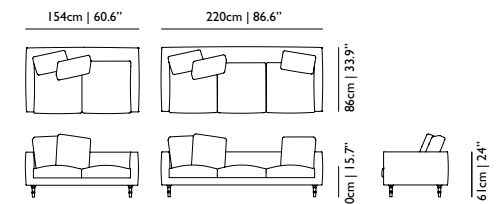
**SOFAS****BART CANAPE**

MOOOIWORKS | BART SCHILDER, 2012
 material: wooden frame covered in foam and dacron, the seat cushion is made in foam.
 material upholstery: see page 205
 colour: various, see page 204

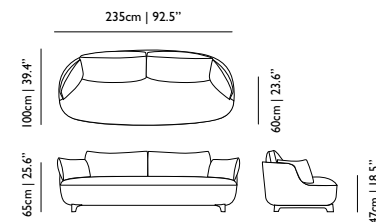
**BOUTIQUE CHAMELEON DIVINA MELANGE 180**

MARCEL WANDERS, 2005
 material: 100% new wool

**BART SOFA**

MOOOIWORKS | BART SCHILDER, 2012
 material: wooden frame covered in foam and dacron, the seat cushion is made in foam.
 material upholstery: see page 205
 colour: various, see page 204

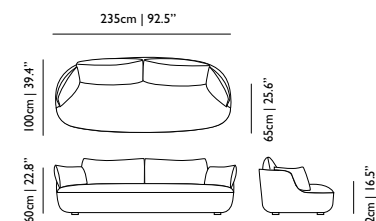
**BOUTIQUE CHAMELEON HALLINGDAL 153**

MARCEL WANDERS, 2005
 material: 70% new wool, 30% viscose

**BART DAYBED**

MOOOIWORKS | BART SCHILDER, 2012
 material: wooden frame covered in foam and dacron, the seat cushion is made in foam.
 material upholstery: see page 205
 colour: various, see page 204

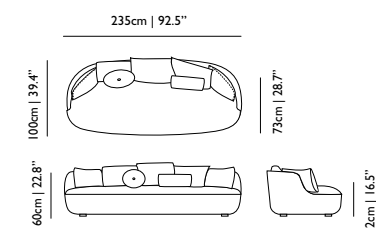
**BOUTIQUE DADDY**

MARCEL WANDERS, 2005
 material: 19% polyester, 15% linen, 51% polyamide





BOUTIQUE DEER

MARCEL WANDERS, 2005
material: 13% polyester, 34% cotton, 15% linen, 35% viscose



BOUTIQUE DELFT BLUE JUMPER

MARCEL WANDERS, 2010
material: 100% new wool,
pillow: 100% polyester



BOUTIQUE DELFT GREY JUMPER

MARCEL WANDERS, 2010
material: 100% new wool,
pillow: 100% polyester



BOUTIQUE DIARY

MARCEL WANDERS, 2005
material: 18% polyester, 46% cotton, 35% viscose, 5% polyamide



BOUTIQUE EASY RIDER

MARCEL WANDERS, 2008
material: 26% polyester, 74% linen



BOUTIQUE JESTER

MARCEL WANDERS, 2005
material: 48% viscose, 50% polyester, 2% polyamide



BOUTIQUE KIMONO

MARCEL WANDERS, 2006
material: 55% polyester, 45% viscose



BOUTIQUE LACE

MARCEL WANDERS, 2006
material: 21% polyester, 27% cotton, 44% linen, 8% viscose



BOUTIQUE LEATHER

MARCEL WANDERS, 2005
material: 100% semi aniline leather
colour: arredo leather, brown, black & white



BOUTIQUE MANGA

MARCEL WANDERS, 2005
material: cover: 29% polyester, 71% cotton,
cushion: 34% polyester, 46% acryl, 20% viscose
pillow: 18% polyester, 46% cotton, 5% polyamide, 31% viscose



BOUTIQUE MEDAILLON

MARCEL WANDERS, 2005
material: cover: 16% polyester, 34% cotton, 15% linen, 35% viscose,
cushion: 34% polyester, 46% acryl, 20% viscose,
pillow: 13% polyester, 34% cotton, 15% linen, 35% viscose



BOUTIQUE NEW YORK

MARCEL WANDERS, 2005
material: 14% polyester, 12% linen, 2% polyamide, 35% acryl, 37% viscose



BOUTIQUE SILVER

MARCEL WANDERS, 2005
material: 50% polyester, 48% viscose, 2% polyamide



BOUTIQUE SOPHY

MARCEL WANDERS, 2008
material: 55% polyester, 29% linen, 1% polyamide, 15% viscose

BOUTIQUE FEET

Boutique feet, Heels (set of 4), chrome
Boutique feet, Pawn (set of 4), black lacquer
Boutique feet, Skis (set of 2), chrome
Boutique feet, Toes (set of 4), black anodized
Boutique feet, Toes (set of 4), chrome



CANVAS SOFA

MARCEL WANDERS, 2012
material: steel box frame covered in foam and dacron
options upholstery: see page 204

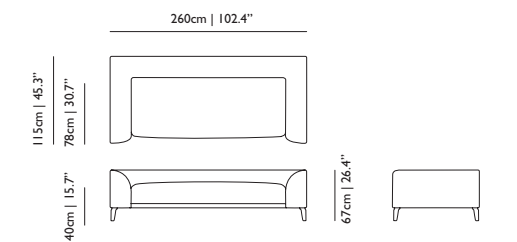

CLOUD SOFA & CLOUD PILLOW

MARCEL WANDERS, 2012
material: steel frame, moulded foam and dacron upholstered, steel connections
material pillows: 35% polyester, 65% viscose
options upholstery: see page 204

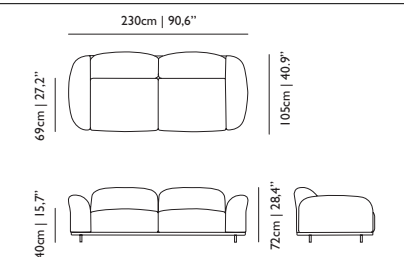

ZLIQ SOFA

MARCEL WANDERS, 2012
material: The Zliq sofa is constructed from a steel box frame covered in foam and dacron, the seat
Zliq is produced with removable covers (please check per category).
Pillows are available seperately.
options upholstery: see page 204

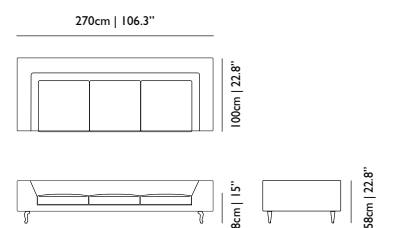



ZLIQ ISLAND

MARCEL WANDERS, 2012
 material: The Zliq sofa is constructed from a steel box frame covered in foam and dacron, the seat Zliq is produced with removable covers (please check per category). Pillows are available seperately.

options upholstery: see page 204

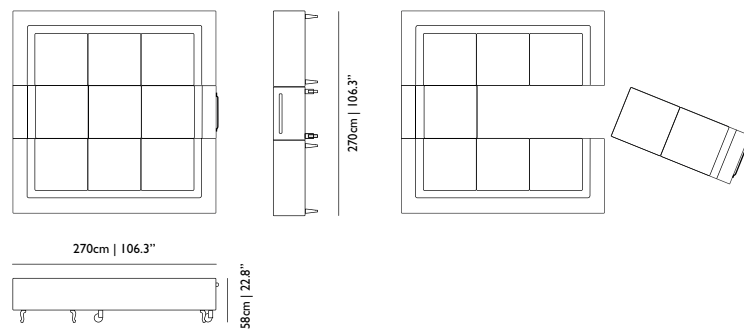

PAPER CABINET
 WHITE, RAL & PATCHWORK

STUDIO JOB, 2005 & 2012
 material: wood and cardboard, finished with paper; polyurethane (PU) and wood veneer
 colour: white, RAL 1004, RAL 1013, RAL 1023, RAL 1027, RAL 2000, RAL 2002, RAL 2004, RAL 3012, RAL 3015, RAL 5003, RAL 5008, RAL 5024, RAL 6010, RAL 6021, RAL 7001, RAL 7011, RAL 7035, RAL 7044, RAL 8001, RAL 8014, RAL 8016, RAL 9005, RAL 9010
 patchwork #03: RAL 1004, RAL 2002, RAL 5024, RAL 6021, RAL 7011, RAL 7035, RAL 8001, RAL 8016, RAL 9010 & oak

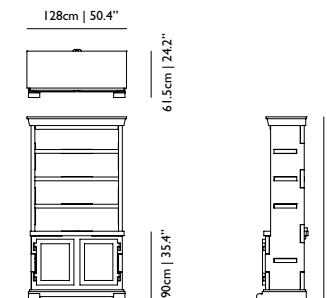

STORAGE



ALTDEUTSCHE CHEST

STUDIO JOB, 2011
 material: solid pine and pine veneer; stained white
 colour: stained white, hand painted art work

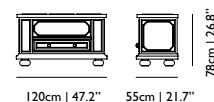

PAPER CABINET
 WHITE, RAL & PATCHWORK

STUDIO JOB, 2005 & 2012
 material: wood and cardboard, finished with paper; polyurethane (PU) and wood veneer
 colour: white, RAL 1004, RAL 1013, RAL 1023, RAL 1027, RAL 2000, RAL 2002, RAL 2004, RAL 3012, RAL 3015, RAL 5003, RAL 5008, RAL 5024, RAL 6010, RAL 6021, RAL 7001, RAL 7011, RAL 7035, RAL 7044, RAL 8001, RAL 8014, RAL 8016, RAL 9005, RAL 9010
 patchwork #03: RAL 1004, RAL 2002, RAL 5024, RAL 6021, RAL 7011, RAL 7035, RAL 8001, RAL 8016, RAL 9010 & oak

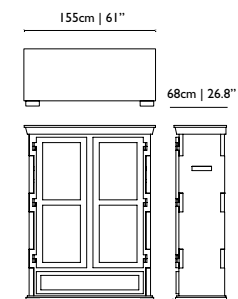

ALTDEUTSCHE CABINET

STUDIO JOB, 2011
 material: solid pine and pine veneer; stained white
 colour: stained white, hand painted art work

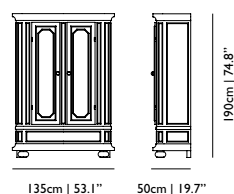

PAPER CABINET
 WHITE, RAL & PATCHWORK

STUDIO JOB, 2005 & 2012
 material: wood and cardboard, finished with paper; polyurethane (PU) and wood veneer
 colour: white, RAL 1004, RAL 1013, RAL 1023, RAL 1027, RAL 2000, RAL 2002, RAL 2004, RAL 3012, RAL 3015, RAL 5003, RAL 5008, RAL 5024, RAL 6010, RAL 6021, RAL 7001, RAL 7011, RAL 7035, RAL 7044, RAL 8001, RAL 8014, RAL 8016, RAL 9005, RAL 9010
 patchwork #03: RAL 1004, RAL 2002, RAL 5024, RAL 6021, RAL 7011, RAL 7035, RAL 8001, RAL 8016, RAL 9010 & oak

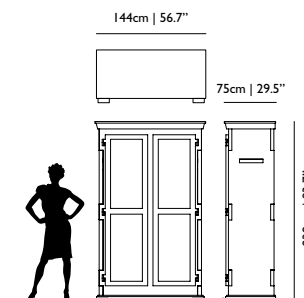

OBLIQUE SMALL

MARCEL WANDERS, 2002
 material: solid oak stained and lacquered or beech lacquered
 colour: black stained, wenge, natural lacquer; white wash, white, red, orange, black

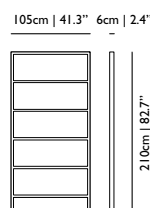

OBLIQUE BIG

MARCEL WANDERS, 2002
 material: solid oak stained and lacquered or beech lacquered
 colour: black stained, wenge, natural lacquer; white wash, white, red, orange, black

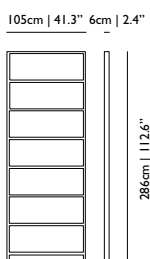

PAPER BUFFET
 WHITE, RAL & PATCHWORK

STUDIO JOB, 2005 & 2012
 material: wood and cardboard, finished with paper; polyurethane (PU) and wood veneer
 colour: white, RAL 1004, RAL 1013, RAL 1023, RAL 1027, RAL 2000, RAL 2002, RAL 2004, RAL 3012, RAL 3015, RAL 5003, RAL 5008, RAL 5024, RAL 6010, RAL 6021, RAL 7001, RAL 7011, RAL 7035, RAL 7044, RAL 8001, RAL 8014, RAL 8016, RAL 9005, RAL 9010
 patchwork #02: RAL 1004, RAL 2002, RAL 5024, RAL 6021, RAL 7001, RAL 7035, RAL 8001, RAL 8016, RAL 9010 & oak

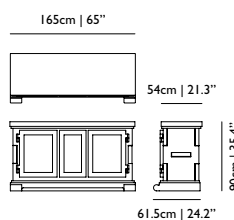

PAPER RAL COLOURS

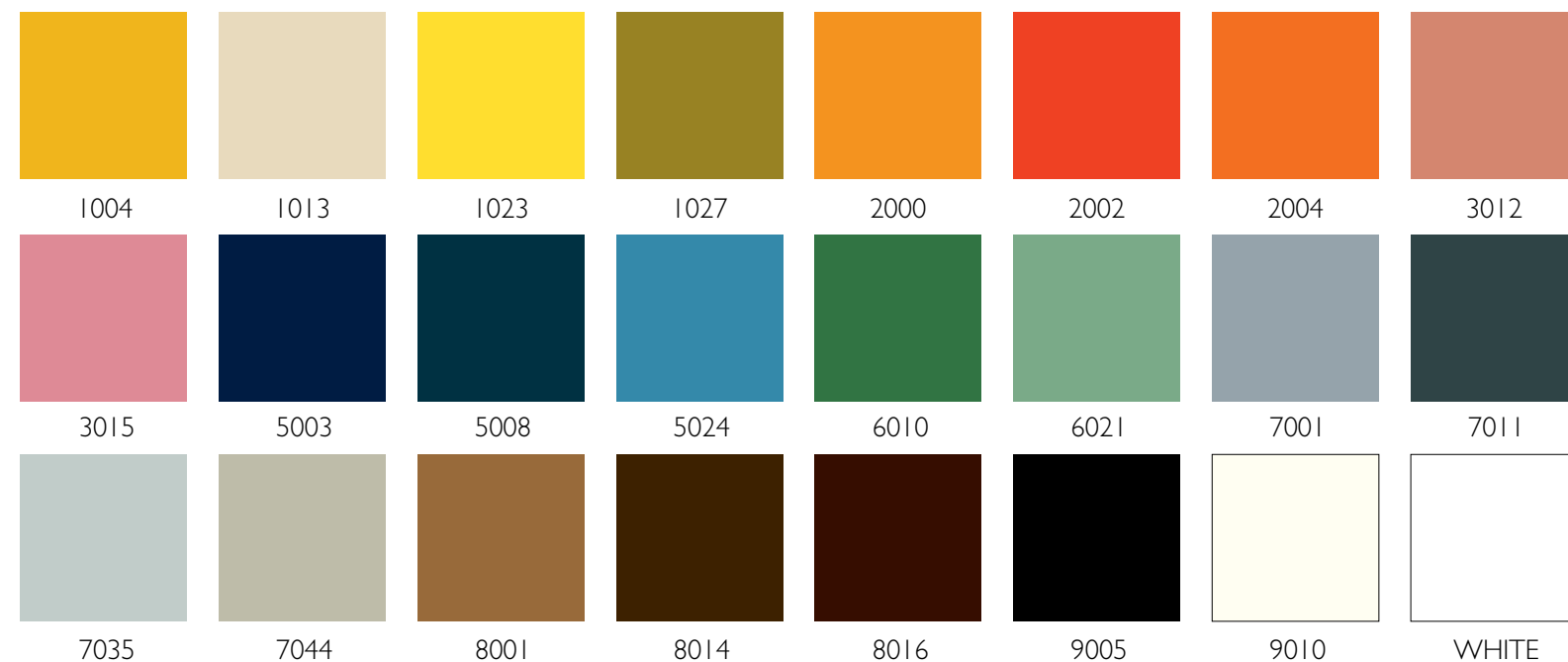

SEATERS TEXTILES & PATTERNS SAMPLES

BOUTIQUE

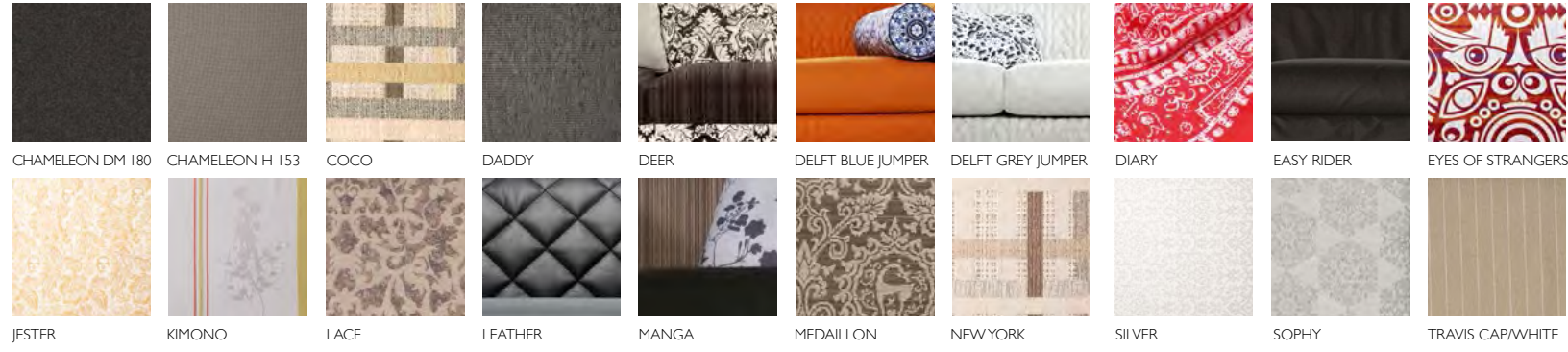

MACCHEDIL, SOTTILE

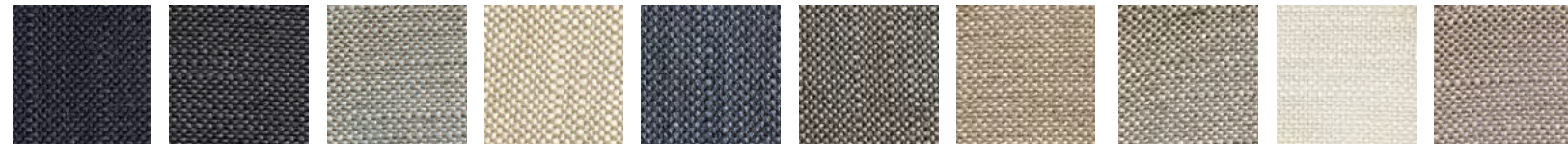

MACCHEDIL, GREZZO

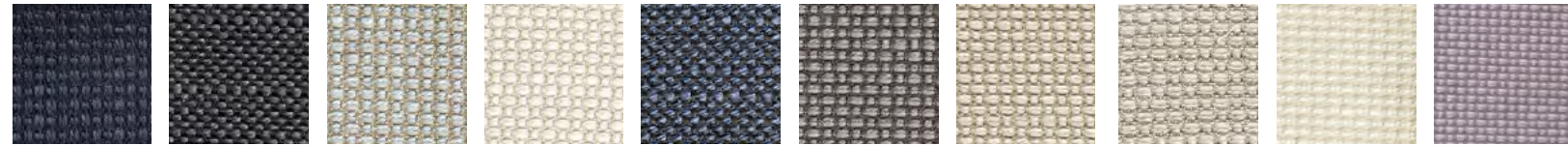

TWILL

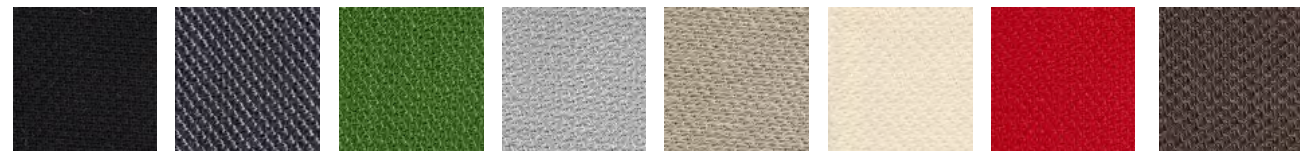

SUMMIT UNI



CERVINO LEATHER

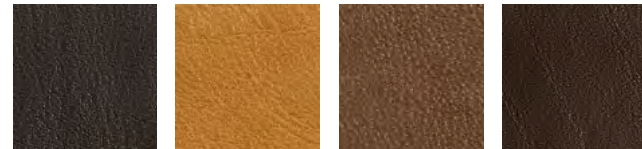

SOFTLINEN



VELOUR

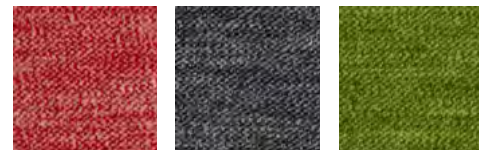

BOUCLÉ



FAUX



ARREDO LEATHER

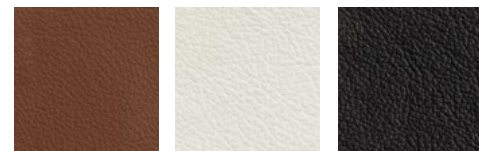

JACQUARD ANDAZ



JACQUARD FRESCO



JACQUARD OLD BLUE



LABYRINTH, ORIGINAL



LABYRINTH, GREY

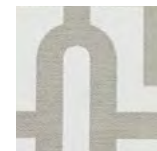

LABYRINTH, INSECT



PAPER PATCHWORK OVERVIEW
STUDIO JOB 2012



PAPER CUPBOARD PATCHWORK



PAPER CHANDELIER PATCHWORK



PAPER TABLE PATCHWORK



PAPER TABLE LAMP PATCHWORK
#8 #9 #10



PAPER WARDROBE PATCHWORK



PAPER SCREEN PATCHWORK



PAPER CABINET PATCHWORK



PAPER BUFFET PATCHWORK



PAPER FLOOR LAMP
PATCHWORK



PAPER SIDE TABLE
PATCHWORK



THANK
YOU
FOR
YOUR
ATTENTION



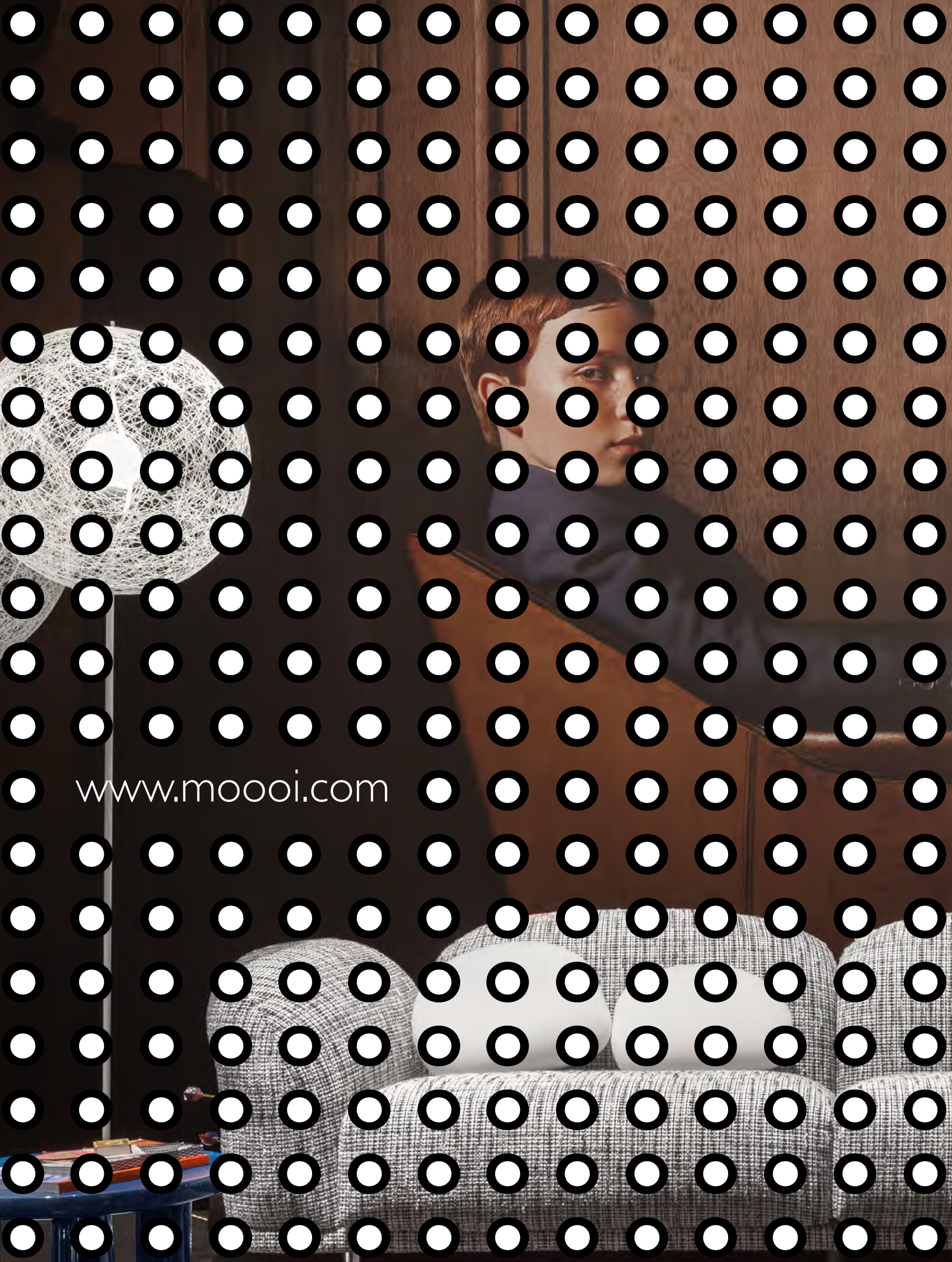

www.moooi.com